

# ***URBANISM WITHOUT DENSITY (?)***

Arch. Rafi Segal, PhD  
*Assoc. Prof. of Architecture and Urbanism,  
Director of SMArchS Urbanism Program, MIT*

*Principal Rafi Segal A + U*

perspective brussels  
November 28, 2019

# Palmach History Museum

Tel Aviv , Israel









# National Library of Israel

Competition, 1<sup>st</sup> Prize









# 20<sup>th</sup> Century Art Museum

Berlin, Germany



In collaboration with DlandStudio

Rafi Segal | Architecture Urbanism



**JWNT**  
Shanghai, China





# Collective Housing

Kibbutz Hatzor, Israel











# Cities of Dispersal

Guest-edited by  
Rafi Segal and Els Verbakel

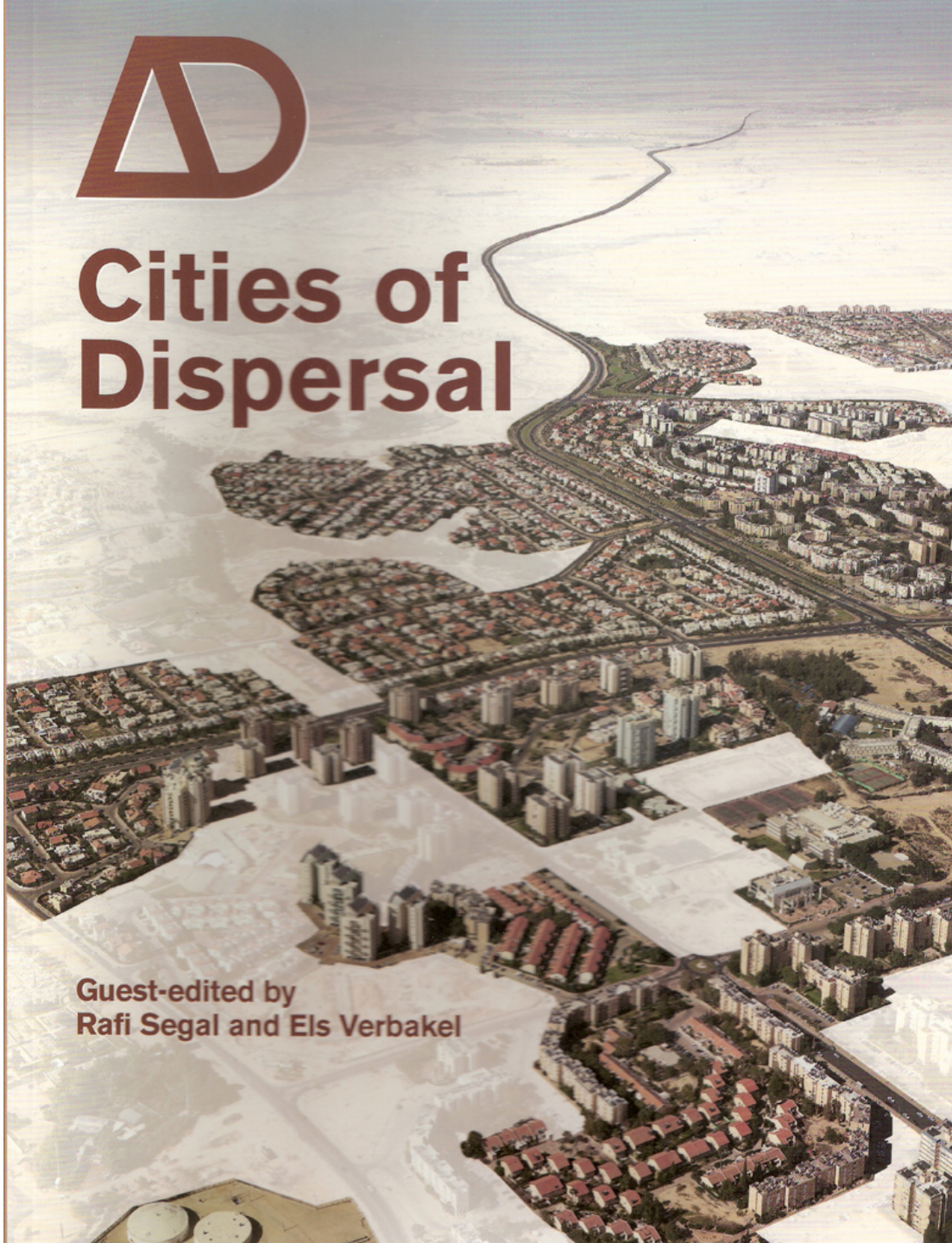



CITY OF PHILADELPHIA  
DENSITY OF VACANT PROPERTIES  
2000

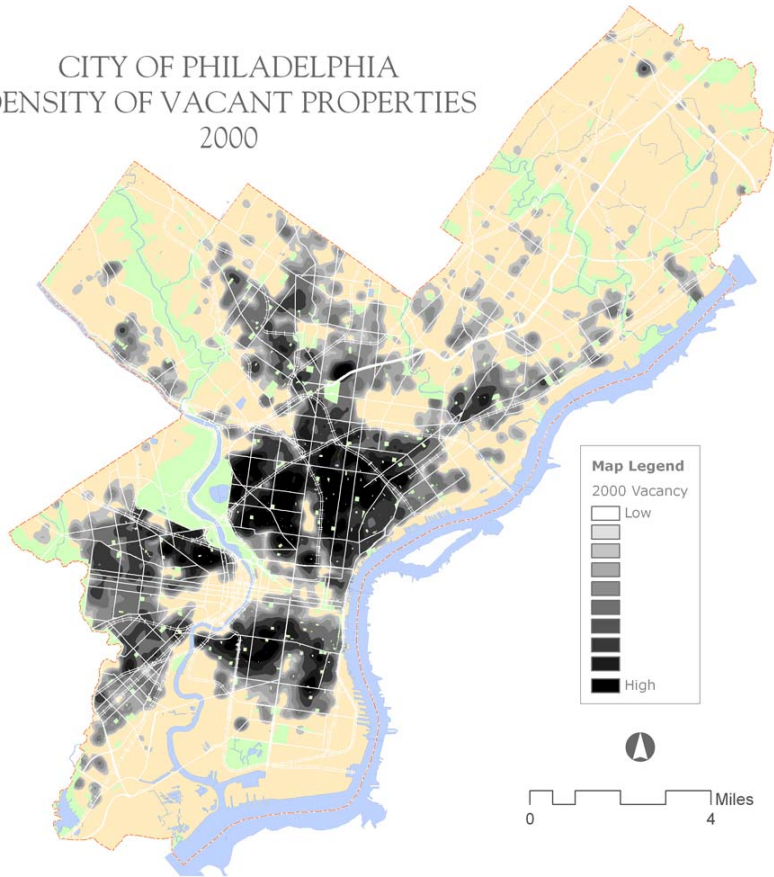

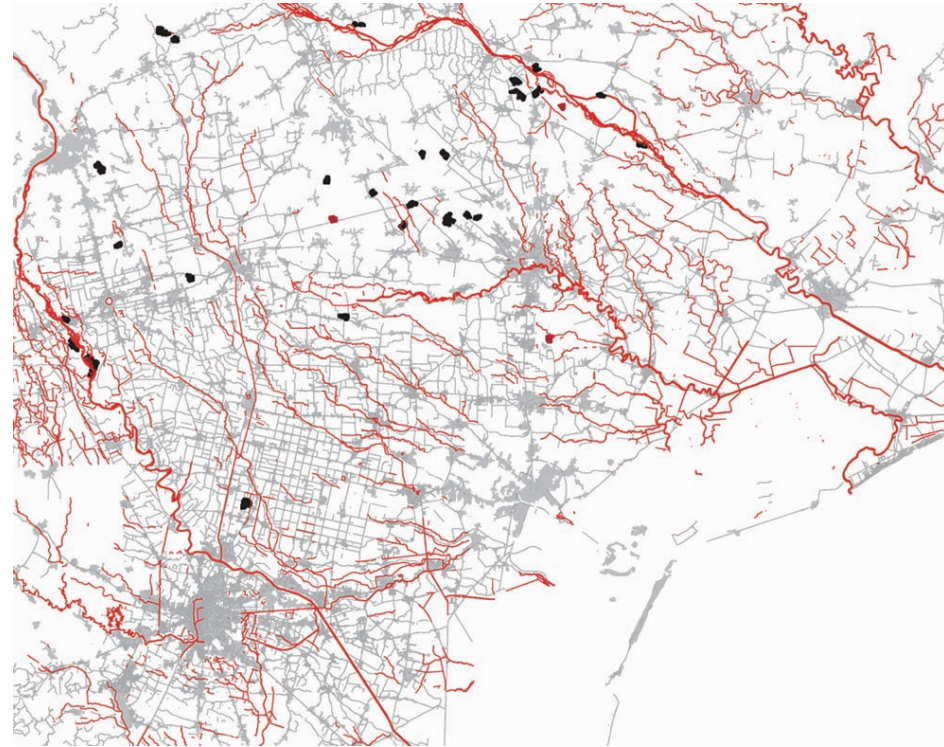



Bruce Robbins  
Albert Pope  
Alex Wall  
Bruno De Meulder  
Paola Vigano  
Kjersti Monson  
Martha Rosler  
Jose Castillo  
Serban Cornea  
Manuel de Solà-Morales  
Zvi Hecker  
Manuel Vicente  
Vito Acconci  
Marcel Smets  
Stan Allen  
Sarah Whiting  
Margaret Crawford

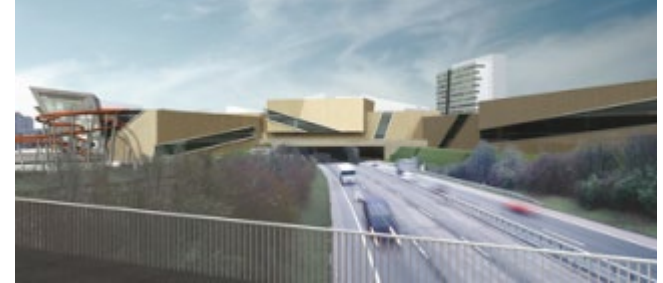

***NEW JERSEY***  
***GARDEN CITY / STATE***







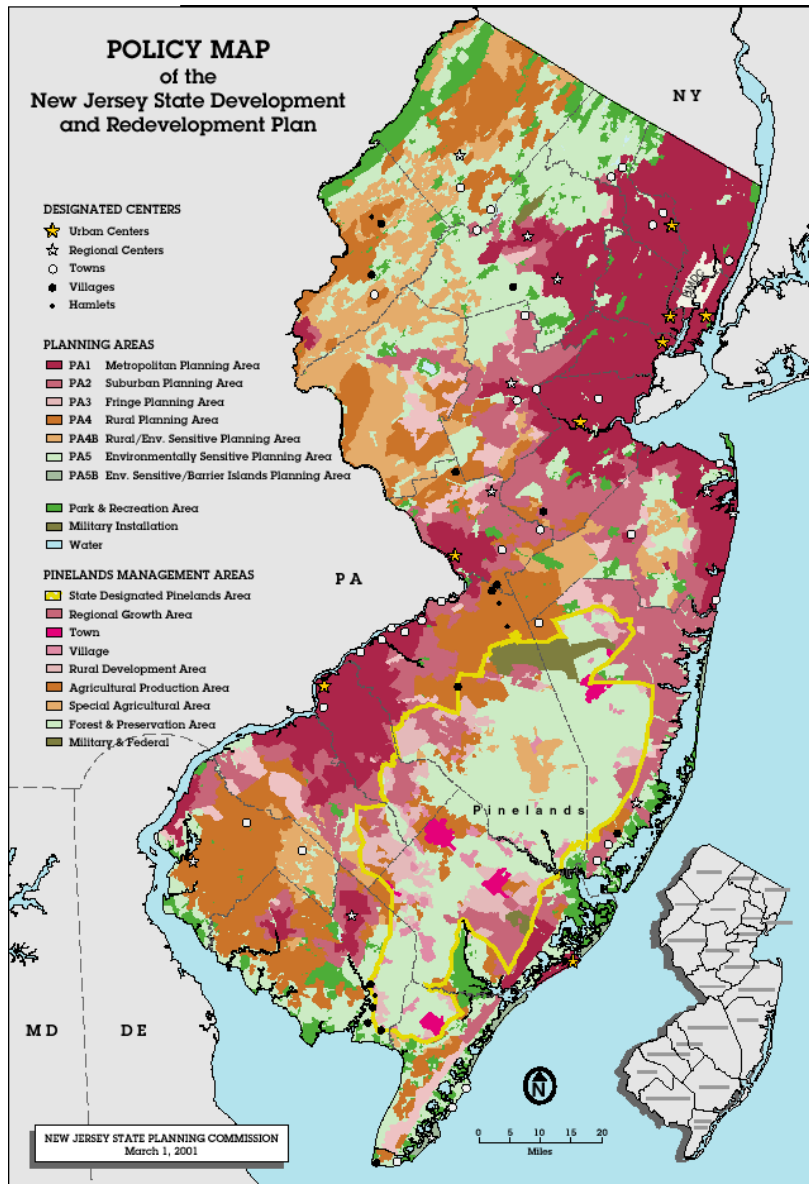

### NEW JERSEY DEVELOPED LAND

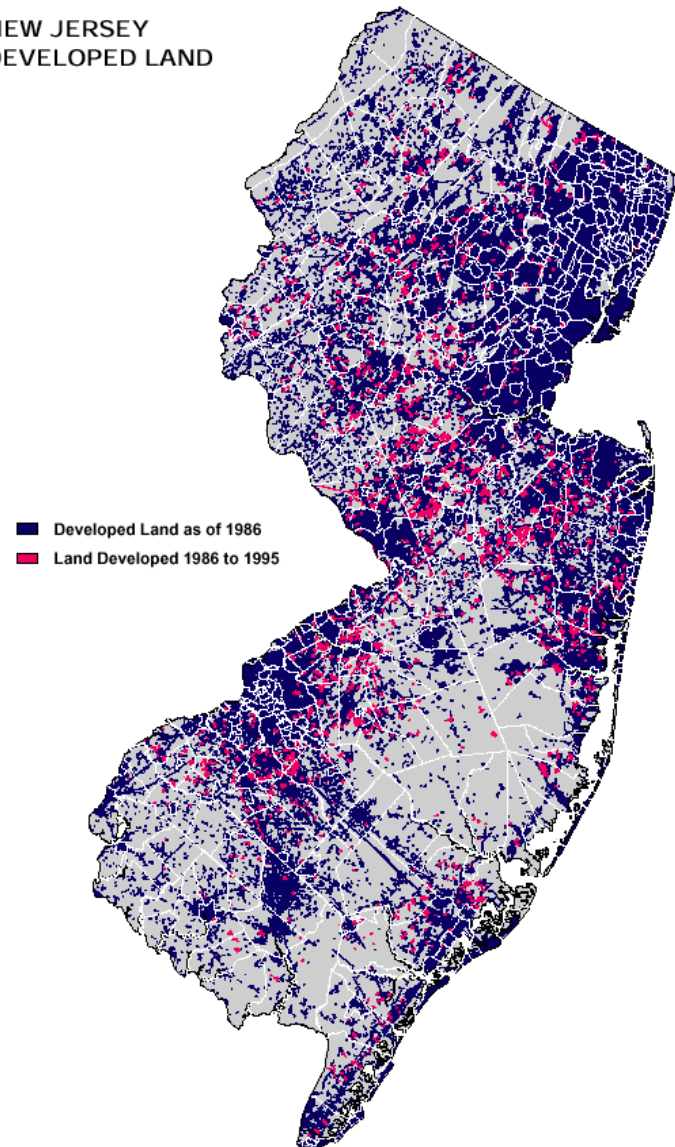

**HIGHWAYS**

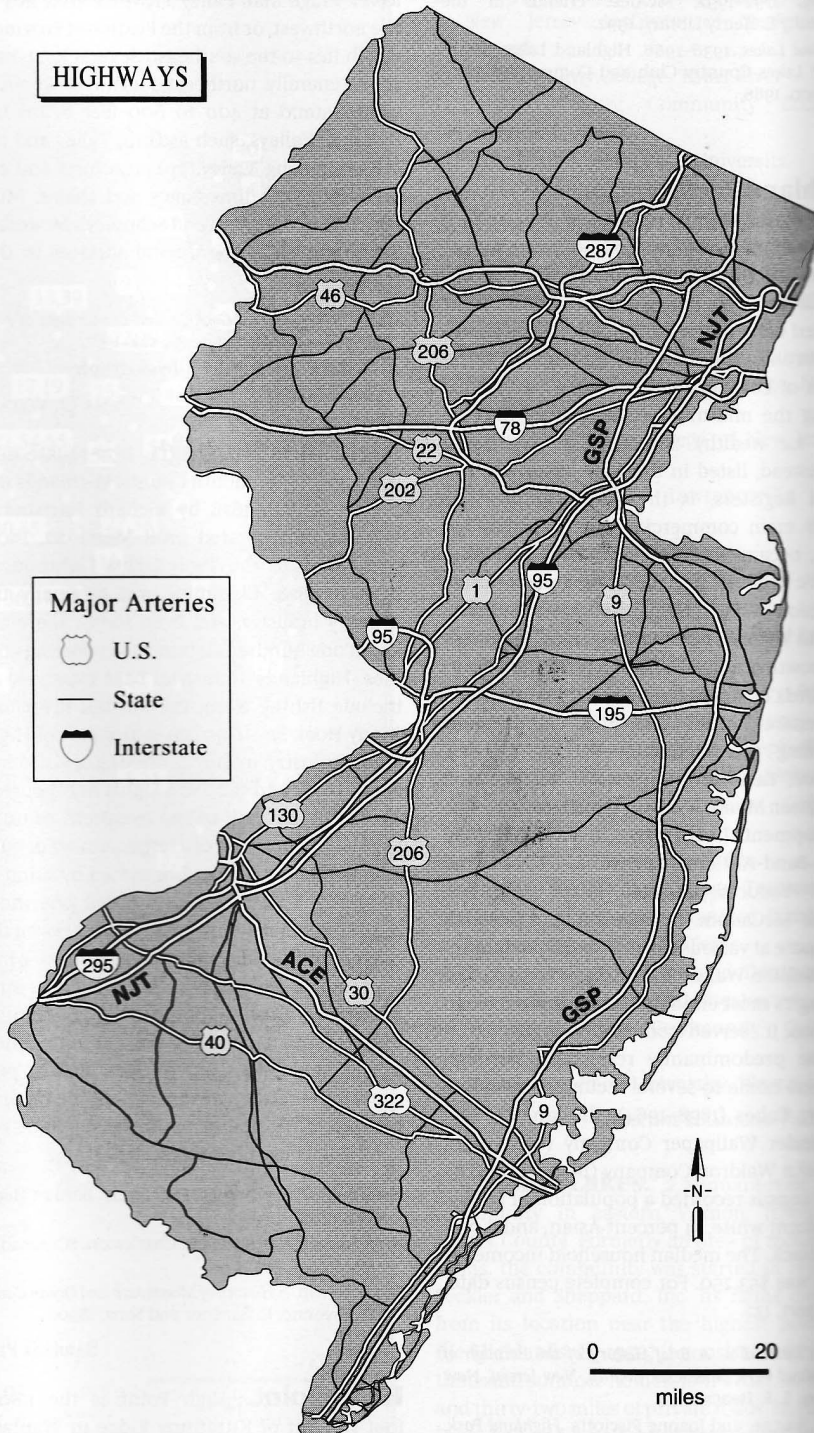

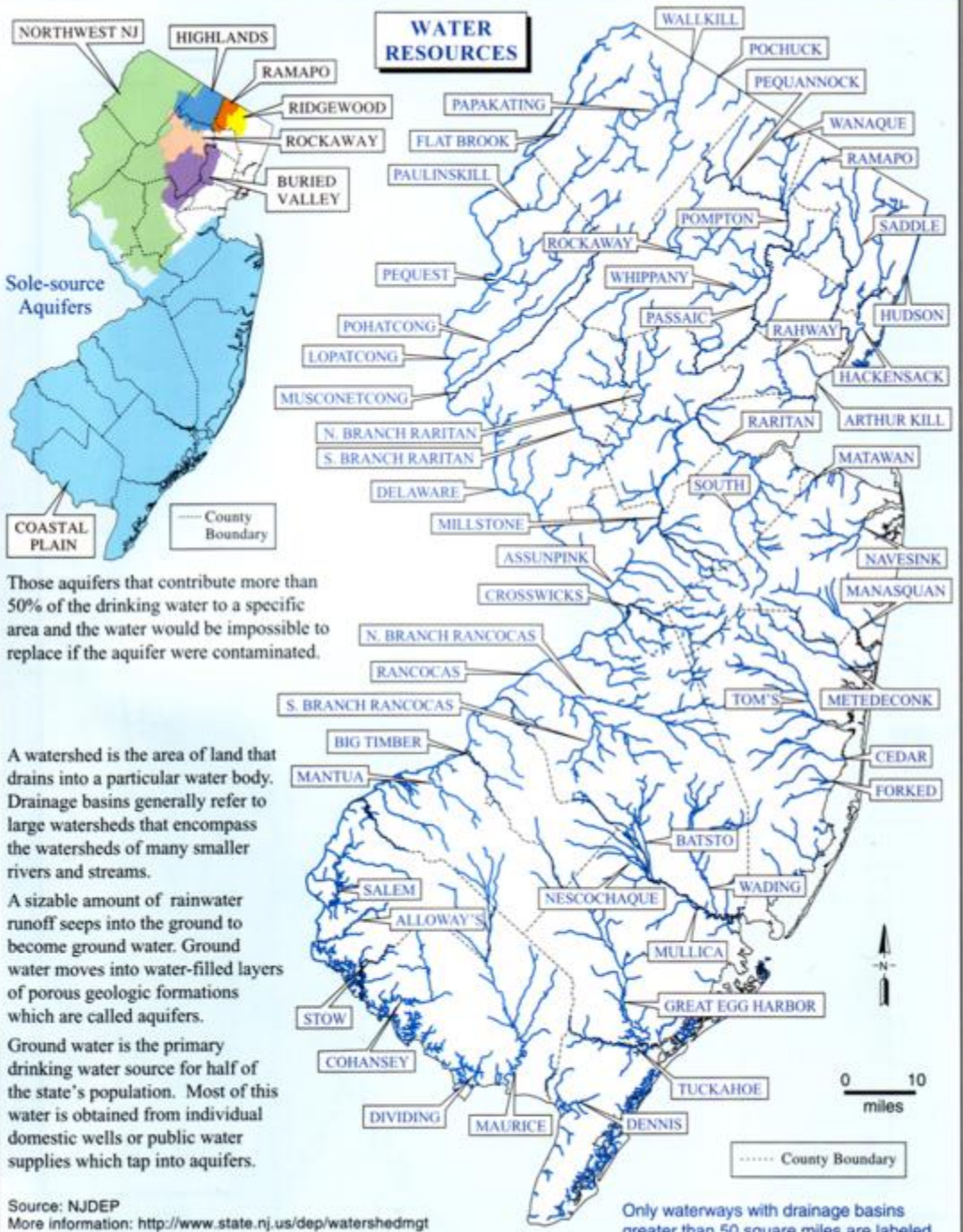

**WATER RESOURCES**

Sole-source Aquifers

Those aquifers that contribute more than 50% of the drinking water to a specific area and the water would be impossible to replace if the aquifer were contaminated.

A watershed is the area of land that drains into a particular water body. Drainage basins generally refer to large watersheds that encompass the watersheds of many smaller rivers and streams.

A sizable amount of rainwater runoff seeps into the ground to become ground water. Ground water moves into water-filled layers of porous geologic formations which are called aquifers.

Ground water is the primary drinking water source for half of the state's population. Most of this water is obtained from individual domestic wells or public water supplies which tap into aquifers.

Source: NJDEP  
 More information: <http://www.state.nj.us/dep/watershedmgt>

Only waterways with drainage basins greater than 50 square miles are labeled.



**AIRPORTS**

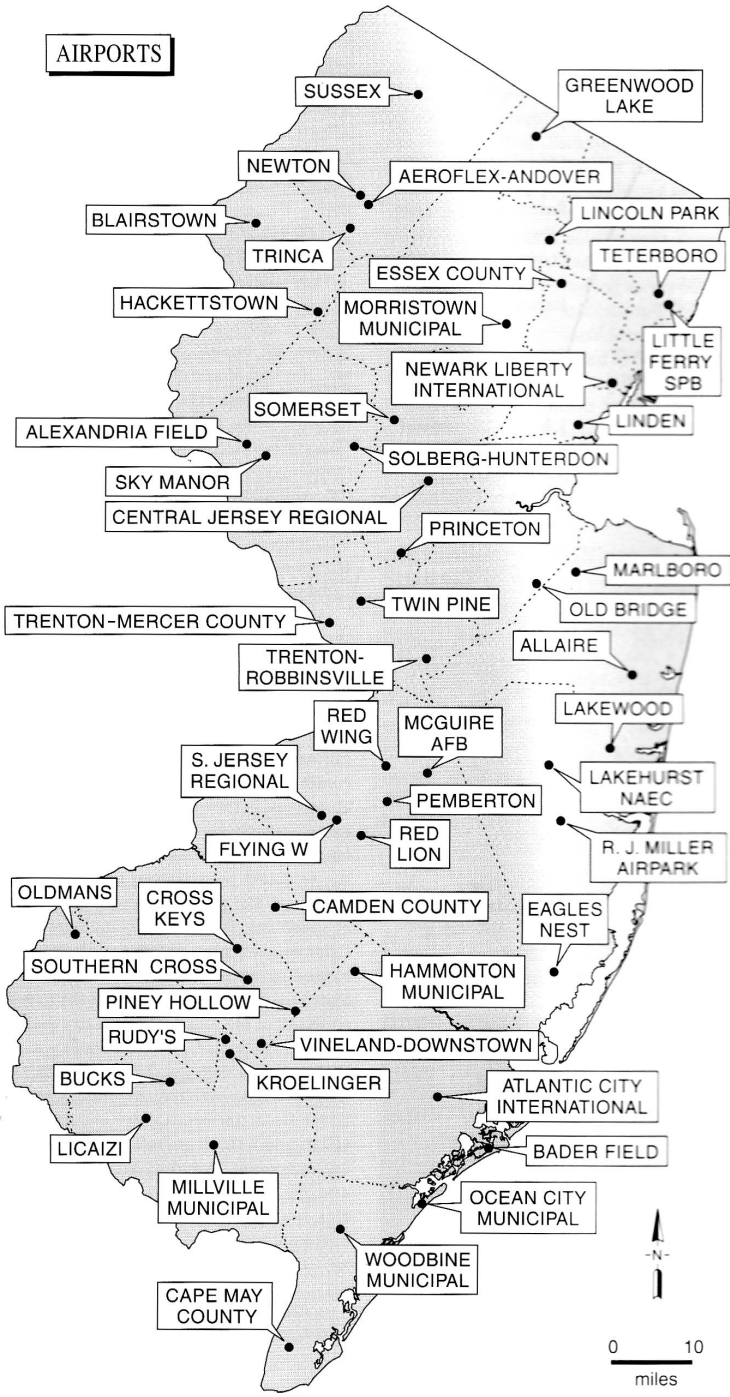

SUPERFUND  
HAZARDOUS  
WASTE SITES

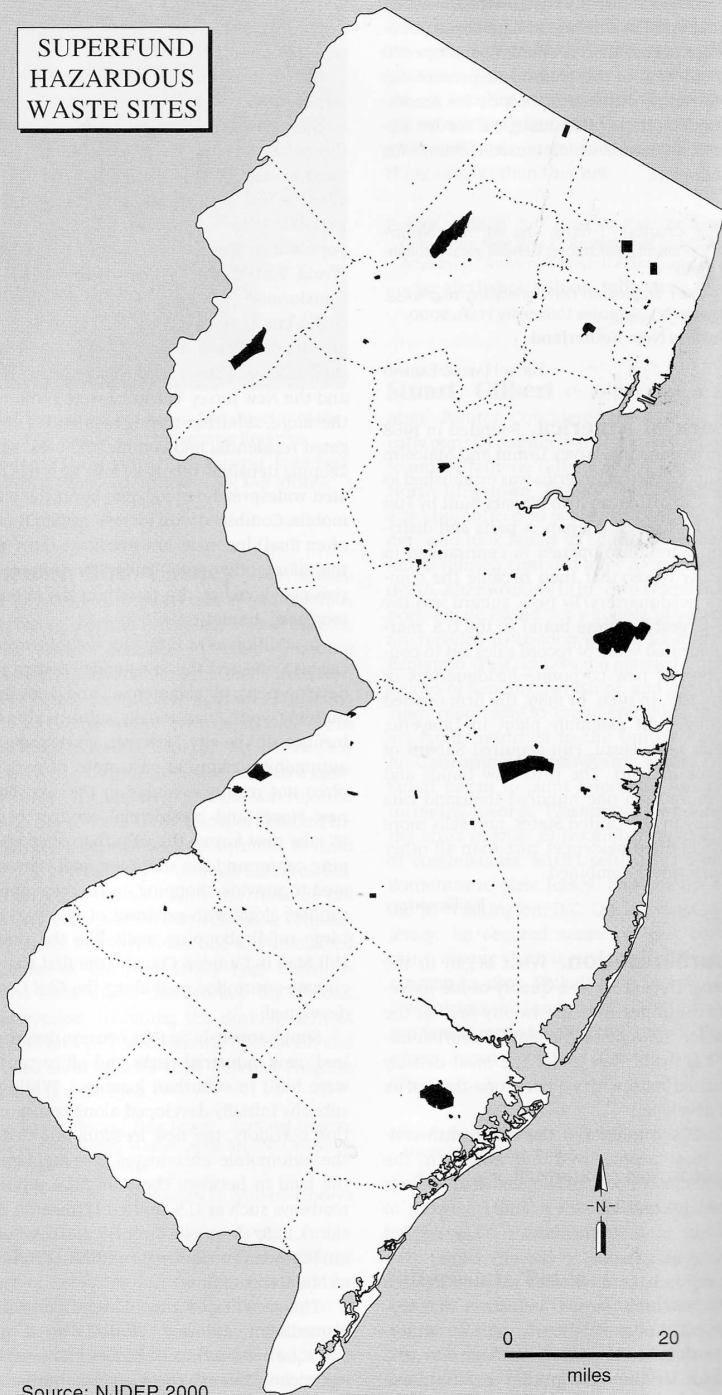

Source: NJDEP 2000



**Municipalities:  
Camden, Gloucester,  
and Salem Counties**

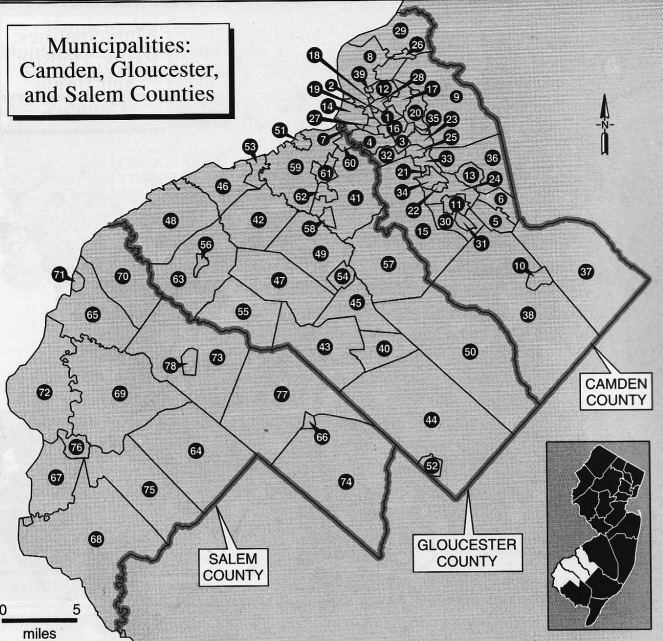

© Rutgers, The State University

- | CAMDEN                 | GLOUCESTER               | SALEM                       |
|------------------------|--------------------------|-----------------------------|
| 1 Audubon Boro         | 40 Clayton Boro          | 64 Alloway Twp              |
| 2 Audubon Park Boro    | 41 Deptford Twp          | 65 Carneys Point Twp        |
| 3 Barrington Boro      | 42 East Greenwich Twp    | 66 Elmer Boro               |
| 4 Bellmawr Boro        | 43 Elk Twp               | 67 Elsinboro Twp            |
| 5 Berlin Boro          | 44 Franklin Twp          | 68 Lower Alloways Creek Twp |
| 6 Berlin Twp           | 45 Glassboro Boro        | 69 Mannington Twp           |
| 7 Brooklawn Boro       | 46 Greenwich Twp         | 70 Oldmans Twp              |
| 8 Camden City          | 47 Harrison Twp          | 71 Penns Grove Boro         |
| 9 Cherry Hill Twp      | 48 Logan Twp             | 72 Pennsville Twp           |
| 10 Chesilhurst Boro    | 49 Mantua Twp            | 73 Pilesgrove Twp           |
| 11 Clementon Boro      | 50 Monroe Twp            | 74 Pittsgrove Twp           |
| 12 Collingswood Boro   | 51 National Park Boro    | 75 Quinton Twp              |
| 13 Gibbsboro Boro      | 52 Newfield Boro         | 76 Salem City               |
| 14 Gloucester City     | 53 Paulsboro Boro        | 77 Upper Pittsgrove Twp     |
| 15 Gloucester Twp      | 54 Pitman Boro           | 78 Woodstown Boro           |
| 16 Haddon Heights Boro | 55 South Harrison Twp    |                             |
| 17 Haddon Twp (east)   | 56 Swedesboro Twp        |                             |
| 18 Haddon Twp (north)  | 57 Washington Twp        |                             |
| 19 Haddon Twp (south)  | 58 Wenonah Boro          |                             |
| 20 Haddonfield Boro    | 59 West Deptford Twp     |                             |
| 21 Hi-Nella Boro       | 60 Westville Boro        |                             |
| 22 Laurel Springs Boro | 61 Woodbury City         |                             |
| 23 Lawnside Boro       | 62 Woodbury Heights Boro |                             |
| 24 Lindenwold Boro     | 63 Woolwich Twp          |                             |
| 25 Magnolia Boro       |                          |                             |
| 26 Merchantville Boro  |                          |                             |
| 27 Mount Ephraim Boro  |                          |                             |
| 28 Oaklyn Boro         |                          |                             |
| 29 Pennsauken Twp      |                          |                             |
| 30 Pine Hill Boro      |                          |                             |
| 31 Pine Valley Boro    |                          |                             |
| 32 Runnemede Boro      |                          |                             |
| 33 Somerdale Boro      |                          |                             |
| 34 Stratford Boro      |                          |                             |
| 35 Tavistock Boro      |                          |                             |
| 36 Voorhees Twp        |                          |                             |
| 37 Waterford Twp       |                          |                             |
| 38 Winslow Twp         |                          |                             |
| 39 Woodlynn Boro       |                          |                             |

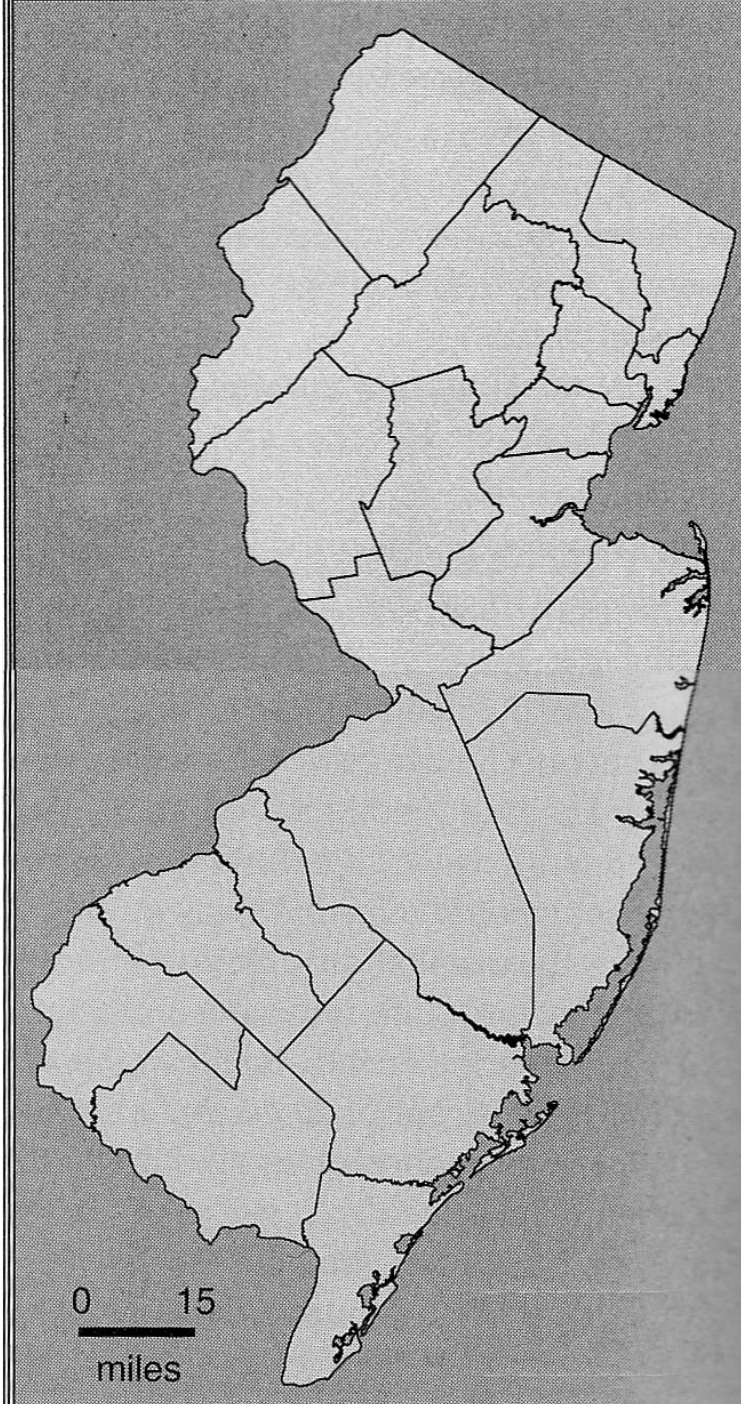

**REGION OF BIRTH OF FOREIGN-BORN POPULATION, 2000**

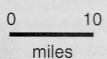
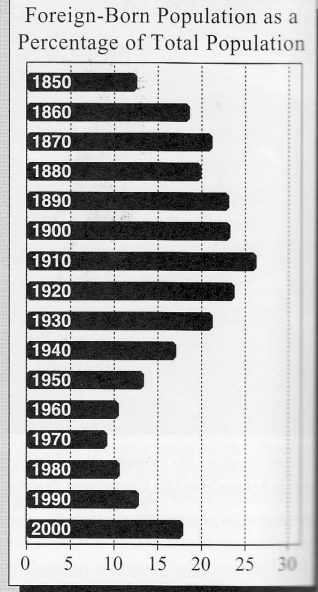
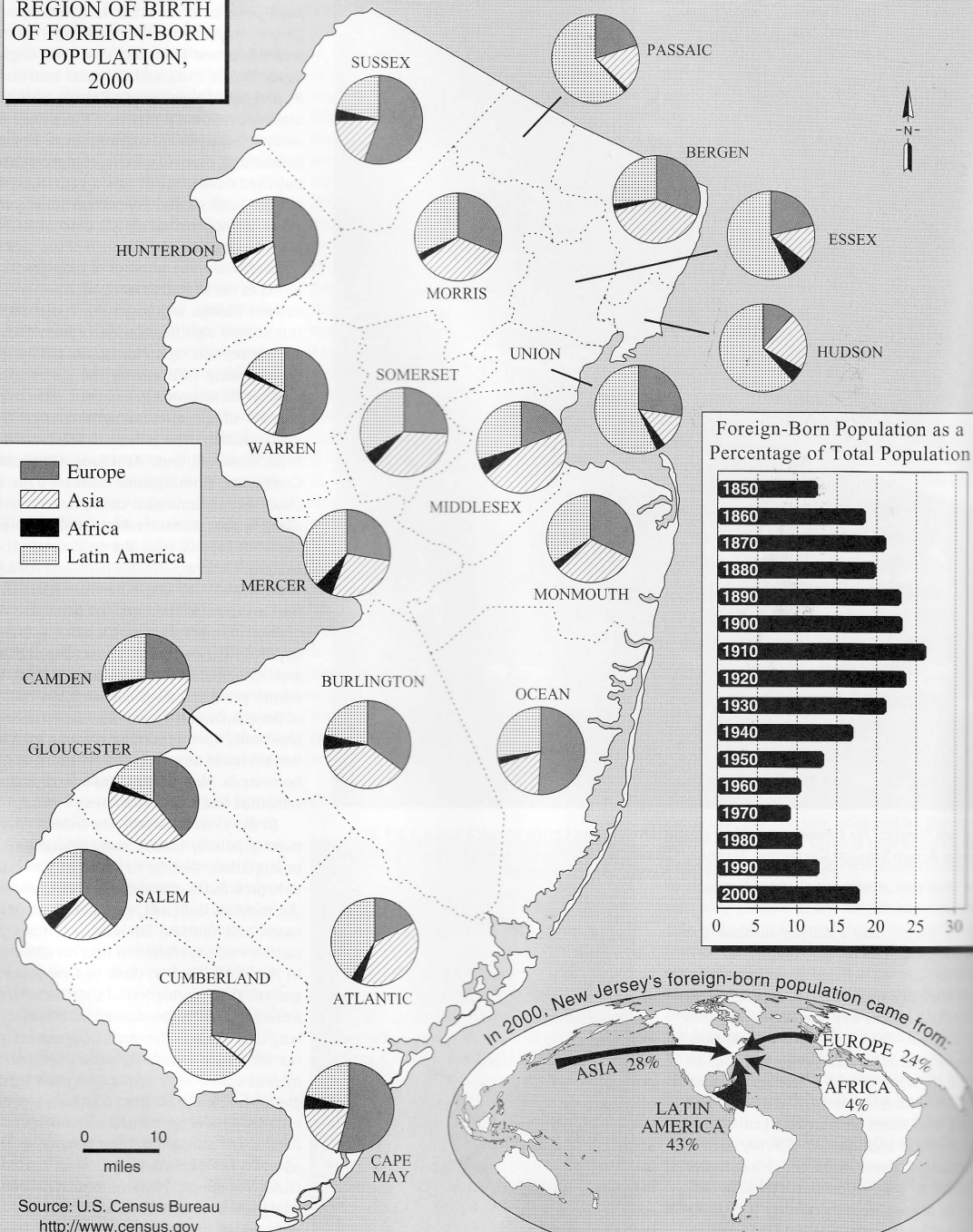
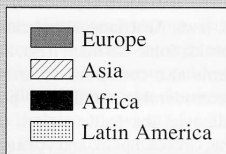

Source: U.S. Census Bureau  
<http://www.census.gov>

Only data for the four largest contributing regions of birth are shown.

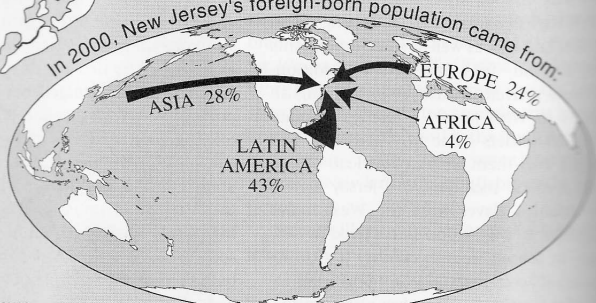

































Trenton/Princeton  
Tickets To Street

RECHARGE STATION  
FOR  
YOUR WIRELESS  
PHONE  
ACCEPTS  
DEBIT CARDS

P

Princeton Junction  
at West Windsor  
NJ 08540

WARNING  
PRIVATE PROPERTY  
NO TRESPASSING  
DANGER  
LIVE WIRE  
ELECTRICAL DANGER  
KEEP OFF

4  
0  
8



EMERGENCY EXIT →

5421

 NJ TRANSIT

PLEASE  
KEEP FEET  
OFF SEATS  



A multitude of:

DENSITIES

NETWORKS

SCALES

ENCLAVES



GARDEN STATE/BACKYARD CITY

A method for urban hybrids of the future Citystate.

The spatial products of New Jersey; objects, buildings, cities, and landscapes, are collected, categorized and dissected into separate architectural elements.

These elements - New Jersey's urban traits - are then combined and mixed to breed new off-springs for a future New Jersey Citystate.

This project proposes a tool for urban speculation and experimentation, whereby the architect generates new urban entities (programs and forms) using units and elements of corporate power and expansion. As New Jersey outgrew its suburban nature, transforming into a new dispersed urban condition, its typical physical features - the generic products created by corporate power, have now become the genes for urban hybrids of a 21st century Citystate.

PRINCETON UNIVERSITY  
CENTER FOR URBANISM,  
ARCHITECTURE  
AND INFRASTRUCTURE

TEAM LEADERS:  
RAFI SEGAL  
ELS VERBAKEL

PROJECT TEAM:  
YAN CHU  
AJAY MANTHAPRAGADA  
MARC McQUADE  
RYAN NEHEISER  
KATE SNIDER  
MICHAEL WANG

DIRECTOR OF CENTER:  
MARIO GANDELONAS

DEAN OF SCHOOL:  
STAN ALLEN

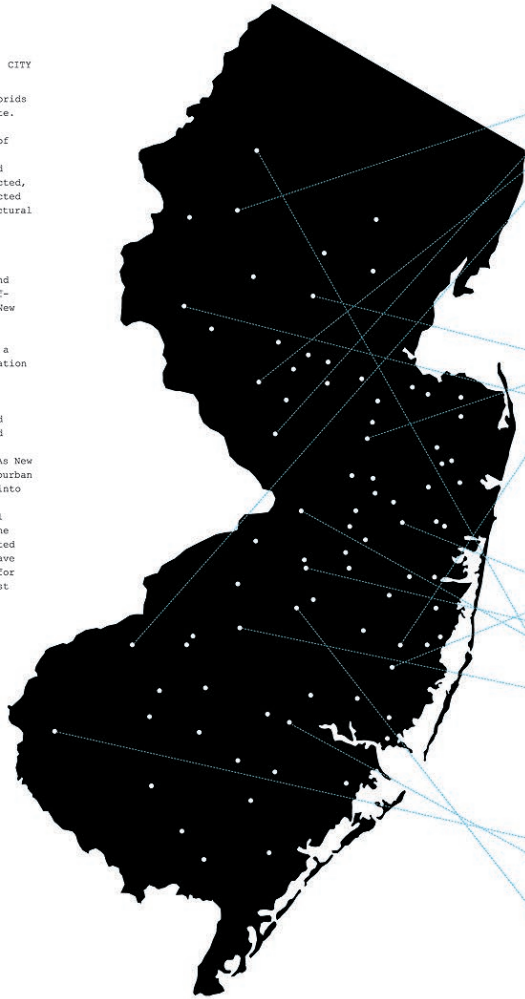

REVERSED CENTRALITIES

GROUP CATALOGS



3b  
0g  
1l  
2a

$$Dh(3b+0g+1l+2a)$$

$$Dh(1-24) = \sum_{i=1}^4 Di(mdi, mdi)$$

1 of 24 COMBINATIONS

JUXTAPositionS OF EXTREME SCALES

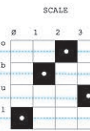

2g  
1b  
3u  
0l

$$Sh(2g+1b+3u+0l)$$

$$Sh(1-24) = \sum_{i=1}^4 Si(nsi, msi)$$

1 of 24 COMBINATIONS

PARALLEL NETWORKS

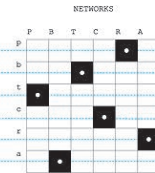

Pp  
Tb  
Fl  
Cc  
Ar  
Ra

$$Np(Rp+Tb+Fl+Cc+Ar+Ra)$$

$$Np(1-720) = \sum_{i=1}^6 Ni(nni, mni)$$

1 of 720 COMBINATIONS

HAZARDS/HAVENS

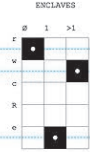

0r  
>1e  
1e

$$Eh(0r+>1e+1e)$$

$$Eh(1-60) = E(0, n) + E(1, n) + E(1, n)$$

1 of 60 COMBINATIONS

GROUP COMBINATIONS

CROSS-GROUP COMBINATIONS

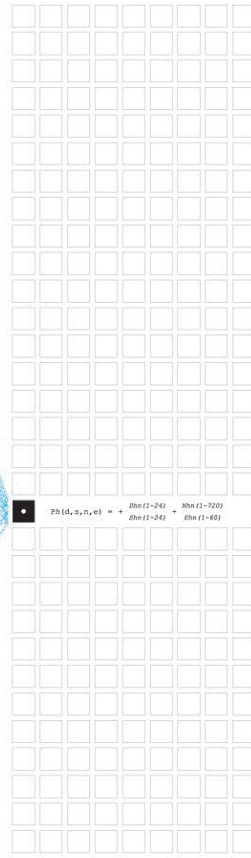

1 of 24,883,200 COMBINATIONS...



DENSITY  $DN(1-24) = \sum_{i=1}^4 D_i(ndi, mdi)$

	Ø LOW	1 MEDIUM	2 HIGH	3 HIGHEST
<b>BUILDING</b> b				
<b>GREEN</b> g				
<b>INFRASTRUCTURE</b> i				
<b>ACTIVITY</b> a				

- b0 - MONROE FANS
- b1 - PRINCETON
- b2 - BRISOL
- b3 - NIAMAK
- g0 - MOUNAUX
- g1 - GREAT SANDS
- g2 - ROUND VALLEY
- g3 - MANSION STATE FOREST
- i0 - 609 SOUTH
- i1 - 202 EAST
- i2 - EXIT 13 I-95
- i3 - NIAMAK LIBERTY INT. AIRPORT
- a0 - UNION CITY PUBLIC LIBRARY
- a1 - POINT PLUMANK BEACH
- a2 - TO BE COLLECTED
- a3 - MANHATTAN ROCK CONCERT

SCALE  $SA(1-24) = \sum_{i=1}^4 S_i(sbi, sbi)$

	Ø SMALL	1 MEDIUM	2 LARGE	3 VERY BIG
<b>OBJECT</b> o				
<b>BUILDING</b> b				
<b>URBAN</b> u				
<b>LANDSCAPE</b> l				

- o0 - LOOPY BEER, EDITION
- o1 - LEAF BLOWER, ACE HANNAH PRINCETON
- o2 - SHIPPING CONTAINERS, PUFFY ESTABLISH
- o3 - LIGHTHOUSE, SANDY HOOK
- b0 - BUS STOP, MARSHON STREET, PRINCETON
- b1 - SINGLE FAMILY HOME, HAMILTON
- b2 - HOME DEPOT, SOUTH BRUNSWICK ROUTE 1
- b3 - STORAGE FACILITY, SPANCOUS
- u0 - PARK BEACH, LOVER'S LANE MARQUAND PARK
- u1 - GAS STATION, ROUTE 130 NORTH
- u2 - DELUXA DRIVE-IN, VENEZIANO
- u3 - NIAMAK LIBERTY INT. AIRPORT
- l0 - FRONT YARD, JAMESBORO
- l1 - SANDS PARK, HACKETTSTOWN
- l2 - BUNGALOW, ATLANTIC CITY
- l3 - PUNJABIANS NATIONAL RESERVE

NETWORKS

$Nb(1-720) = \sum_{i=1}^6 N_i(nbi, nbi)$

	P PEDESTRIAN	B BOAT	T TRUCK	C CAR	R RAIL	A AIR
<b>PEDESTRIAN</b> p						
<b>BOAT</b> b						
<b>TRUCK</b> t						
<b>CAR</b> c						
<b>RAIL</b> r						
<b>AIR</b> a						

- pP - SISKIWA, HOSWELL
- pB - ELLIS ISLAND FERRY, LIBERTY PARK
- pT - MONTANA CAR LEASING DOCK, PRINCETON
- pC - FURST EDEMSBERG STATION, MONTROSE
- pR - TO BE COMPLETED
- pA - LAMELAND AIRCRAFT MOBILE, EXIAL
- bP - HANSON PARK CANOE CLUB, CHANFORD
- bB - THE NIAMAK MARSHWAY
- bT - TRAIL SWIMMA, PALMATIC RIVER
- bC - HOLLAND TUNNEL, HUDSON RIVER
- bR - RAIFAN RIVER, NEW BRUNSWICK
- bA - SEAFARNE BASIN, JERSEY CITY
- tP - AXEL CALSON REEF, NEAR MANHATTAN ISLAND
- tB - FINE BILLOMERS, ELIZABETH
- tC - EXIT 10, 295 SOUTH
- tR - NEW JERSEY TOWNSHIP, MUFF CHANGE
- tA - TO BE COMPLETED
- tL - HELICOPTER NJ, MONTROSE
- tP - PUBLIC LANDS, HONOLULU
- cT - JERSEY BRIDGES, NJ TOWNSHIP
- cC - INTERSECTION, CHANSON
- cR - ALBANY ROAD, PRINCETON
- oA - HELICOPTER, ATLANTIC CITY AIRPORT
- pP - TRAIN STATION, PRINCETON JUNCTION
- rB - TO BE COMPLETED
- rT - KILMAY STATION, NJ TOWNSHIP
- rC - TO BE COMPLETED
- rR - TRAIN STATION, MONTROSE
- rA - ABOVE EXIT 14, NJ TOWNSHIP
- aP - GATE 27, NIAMAK LIBERTY INT. AIRPORT
- oB - NY SHIP BUILDING CORPORATION, CANON
- aT - HESS CORPORATION, TOWNSHIP
- aC - CANT GUARD STATION, ATLANTIC CITY
- aR - AIR SHUTTLE, NIAMAK LIBERTY INT. AIRPORT
- aA - MICHIGAN AIR FORCE BASE, WASHINGTON
- rP - SOUTH WOOD STATE PRISON, BRIDGEBORO
- rL - LEWISTOWN, WASHINGTON
- rP1 - "LITTLE LEM" PUNJABI ENCLAVE, PATERSON
- wP - PUFF DIX ARMY BASE, BURLINGAME COUNTY
- w1 - BRIDGE-MAN SOUVENIR, PRINCETON TOWNSHIP
- wP1 - OFFICE BUILDING, TO BE COLLECTED
- rB - INTERMET RETAILER
- c1 - ALBANY BRIDGE ROAD AREA, NJ TOWNSHIP
- oP1 - CHEVY HILL MALL, BURLINGAME COUNTY
- R1 - CHURCH OF THE HELIX, FENWELL
- R1 - TRUMP PLAZA HOTEL & CASINO, ATLANTIC CITY
- R>1 - HIDDEN ACRES CAMP GROUND, CAPE MAY
- oB - MANHATTAN, KANSAS
- o1 - KALDI PAPER CELL REFINERY, WESTVILLE
- oP1 - CAPE MAY

ENCLAVES  $EN(1-60) = E(6, n) * E(1, n) * E(1, n)$

	Ø ENTRIES	1 ENTRY	>1 ENTRY
<b>RESIDENTIAL</b> r			
<b>WORK</b> w			
<b>COMMERCIAL</b> c			
<b>RECREATION</b> r			
<b>ECOLOGICAL</b> e			

- rP - SOUTH WOOD STATE PRISON, BRIDGEBORO
- rL - LEWISTOWN, WASHINGTON
- rP1 - "LITTLE LEM" PUNJABI ENCLAVE, PATERSON
- wP - PUFF DIX ARMY BASE, BURLINGAME COUNTY
- w1 - BRIDGE-MAN SOUVENIR, PRINCETON TOWNSHIP
- wP1 - OFFICE BUILDING, TO BE COLLECTED
- rB - INTERMET RETAILER
- c1 - ALBANY BRIDGE ROAD AREA, NJ TOWNSHIP
- oP1 - CHEVY HILL MALL, BURLINGAME COUNTY
- R1 - CHURCH OF THE HELIX, FENWELL
- R1 - TRUMP PLAZA HOTEL & CASINO, ATLANTIC CITY
- R>1 - HIDDEN ACRES CAMP GROUND, CAPE MAY
- oB - MANHATTAN, KANSAS
- o1 - KALDI PAPER CELL REFINERY, WESTVILLE
- oP1 - CAPE MAY



DENSITY

$$Dh(1-24) = \sum_{i=1}^4 D_i(nd_i, md_i)$$

∅ LOW

1 MEDIUM

2 HIGH

3 HIGHEST

BUILDING

b



b0 - MEADFORD FARMS

b1 - PRINCETON

b2 - EDISON

b3 - NEMARK

GREEN

g

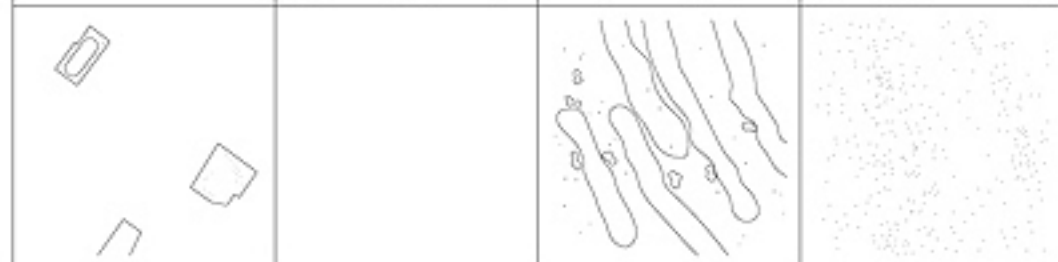

g0 - MENDHAM

g1 - GREAT SWAMP

g2 - ROUND VALLEY

g3 - NEANTON STATE FOREST

INFRASTRUCTURE

i



i0 - 609 SOUTH

i1 - 202 EAST

i2 - EXIT 13 I-95

i3 - NEMARK LIBERTY INT. AIRPORT

ACTIVITY

a

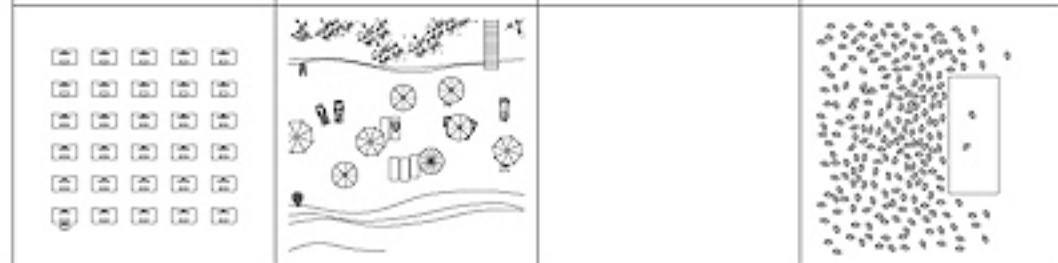

a0 - UNION CITY PUBLIC LIBRARY

a1 - POINT PLEASANT BEACH

a2 - TO BE COLLECTED

a3 - MEADOWLANDS ROCK CONCERT



Dh ( $\emptyset i+1a+2b+3g$ )



Dh ( $\emptyset b+1a+2g+3i$ )



Dh ( $\emptyset a+1b+2g+3i$ )

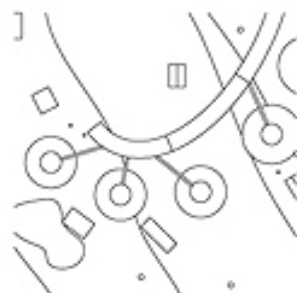

Dh ( $\emptyset g+1b+2a+3i$ )

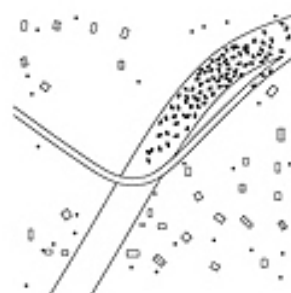

Dh ( $\emptyset b+1g+2i+3a$ )



Dh ( $\emptyset i+1b+2g+3a$ )



Dh ( $\emptyset i+1a+2g+3b$ )



Dh ( $\emptyset g+1a+2i+3b$ )



Dh ( $\emptyset a+1b+2i+3g$ )





GROUP COMBINATIONS



Dh (D1+1a+2b+3g)



Dh (Dh+1a+2g+3i)



Dh (Dh+1b+2g+3i)

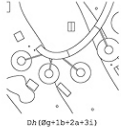

Dh (Dg+1b+2a+3i)



Dh (Dh+1g+2i+3a)



Dh (Dl+1b+2g+3a)



Dh (Dl+1a+2g+3b)



Dh (Dg+1a+2i+3b)



Dh (Dh+1b+2i+3g)



Nh (Fh+Dc+Tb+Dp+Rt+As)

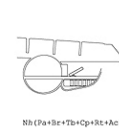

Nh (Fh+Dc+Tb+Dp+Rt+As)

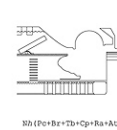

Nh (Fh+Dc+Tb+Dp+Rt+As)

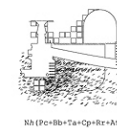

Nh (Fh+Dc+Tb+Dp+Rt+As)

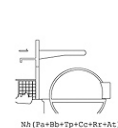

Nh (Fh+Dc+Tb+Dp+Rt+As)

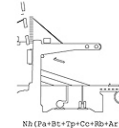

Nh (Fh+Dc+Tb+Dp+Rt+As)

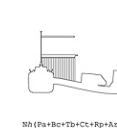

Nh (Fh+Dc+Tb+Dp+Rt+As)



Nh (Fh+Dc+Tb+Dp+Rt+As)



Nh (Fh+Dc+Tb+Dp+Rt+As)



Nh (Fh+Dc+Tb+Dp+Rt+As)

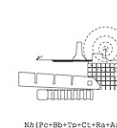

Nh (Fh+Dc+Tb+Dp+Rt+As)

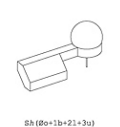

Sh (Dh+1b+2i+3a)



Sh (Dh+1a+2i+3a)



Sh (Dh+1a+2b+3i)



Sh (Dl+1a+2b+3b)



Sh (Dh+1c+>1R)



Sh (Dh+1a+>1e)

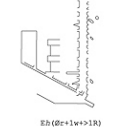

Sh (Dh+1a+>1R)



Sh (Dh+1a+>1c)



Sh (Dh+1a+2b+3i)



Sh (Dh+1i+2a+3a)



Sh (Dh+1b+2a+3i)

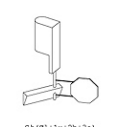

Sh (Dl+1a+2b+3b)

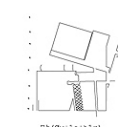

Sh (Dh+1a+>1c)



Sh (Dh+1R+>1e)

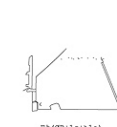

Sh (Dh+1c+>1e)



Sh (Dh+1e+>1R)

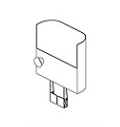

Sh (Dh+1i+2a+3b)



Sh (Dh+1b+2i+3b)



Sh (Dh+1c+>1R)



Sh (Dh+1c+>1R)



Sh (Dh+1c+>1c)



Sh (Dh+1c+>1c)



CROSS-GROUP COMBINATIONS

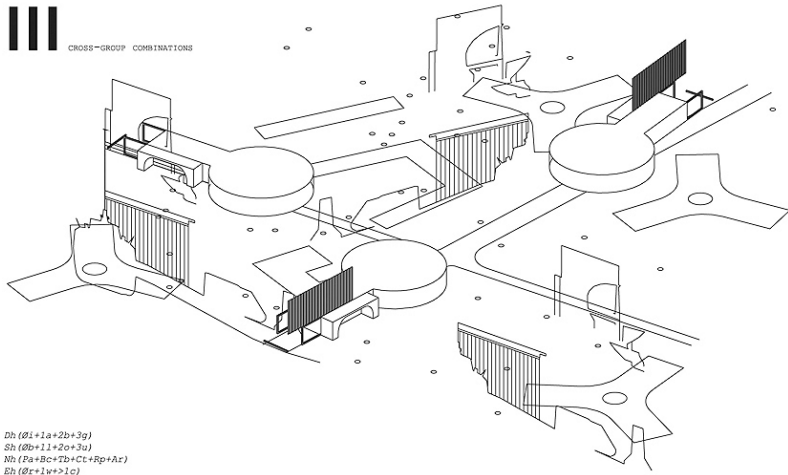

Dh (0i+1a+2b+3g)  
Sh (0b+1j+2o+3a)  
Nl (2a+Bc+2b+Ct+Rp+Ar)  
Eh (0z+1w+1c)

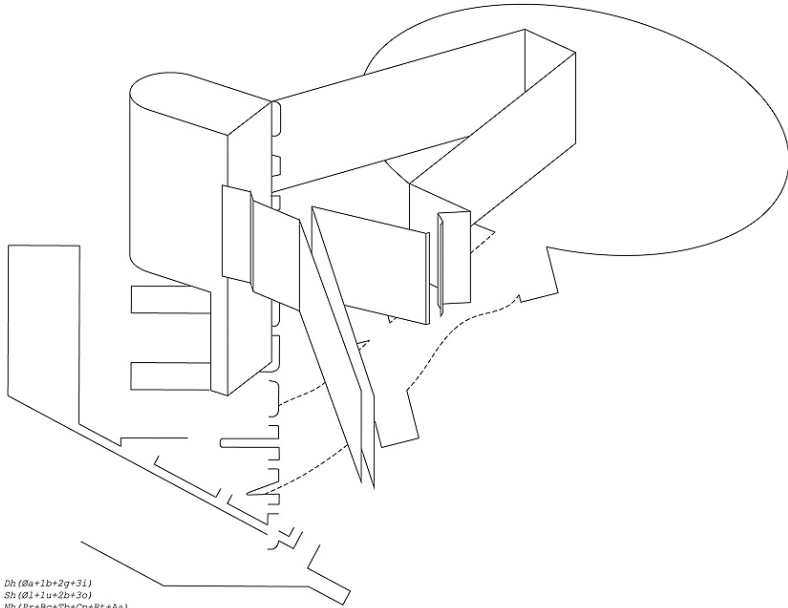

Dh (0a+1b+2g+3j)  
Sh (0i+1u+2b+3o)  
Nl (2c+Bc+2b+Cp+Rt+Ar)  
Eh (0z+1w+>1R)

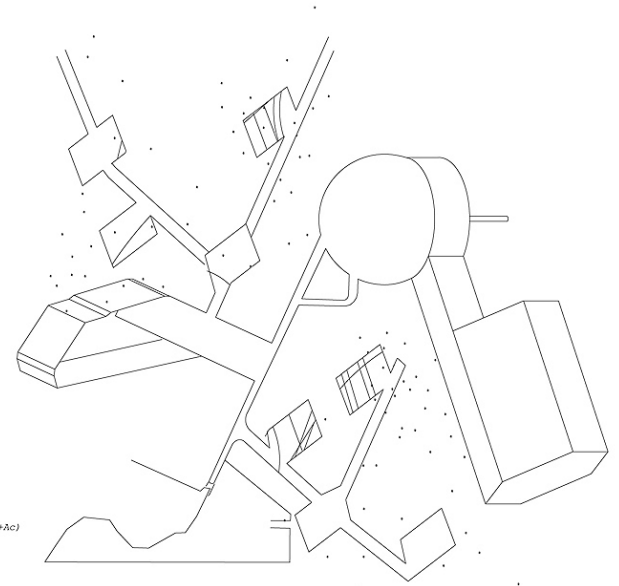

Dh (0a+1b+2i+3g)  
Sh (0b+1b+2i+3a)  
Nl (2a+Bc+2b+Cp+Rt+Ac)  
Eh (0R+1c+>1r)

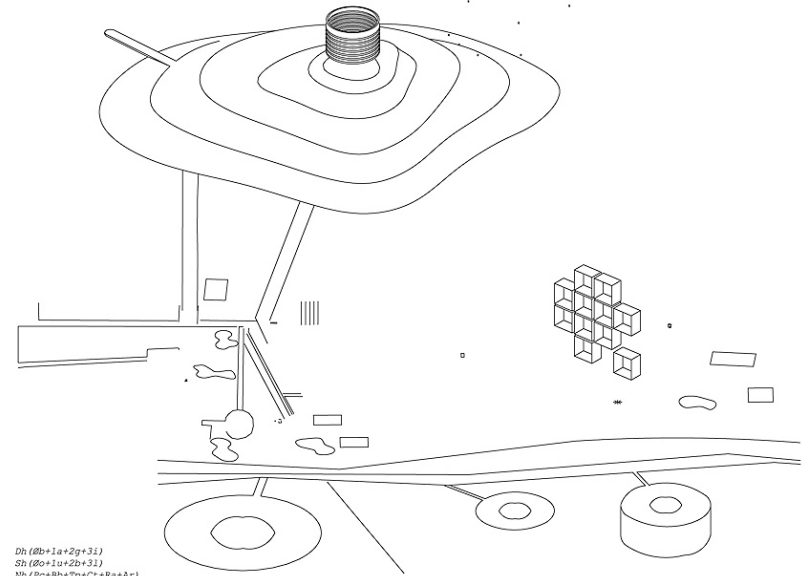

Dh (0b+1a+2g+3j)  
Sh (0b+1u+2b+3j)  
Nl (2c+Bb+2p+Ct+Ra+Ar)  
Eh (0R+1z+>1c)





SHARENESS

REDUNDANCY

MULTITUDE OF SCALES

BEARINGS

FLUCTUATION: GROWTH & DECAY

HETEROGENITY

SIMULTANEITY

CONFLICT

ANONYMITY



***AUTOMATED VEHICLES  
(AV LEVEL 5)  
SUBURBAN CONVERSIONS***





# **30-Minute City** **Polycentric Urbanism in the Moreton Bay Region,** **Queensland Australia**



*Rafi Segal, Alan Berger, Jonah Susskind*



# Example 1, Suburban Housing in Moreton Bay Australia

## Existing Layout

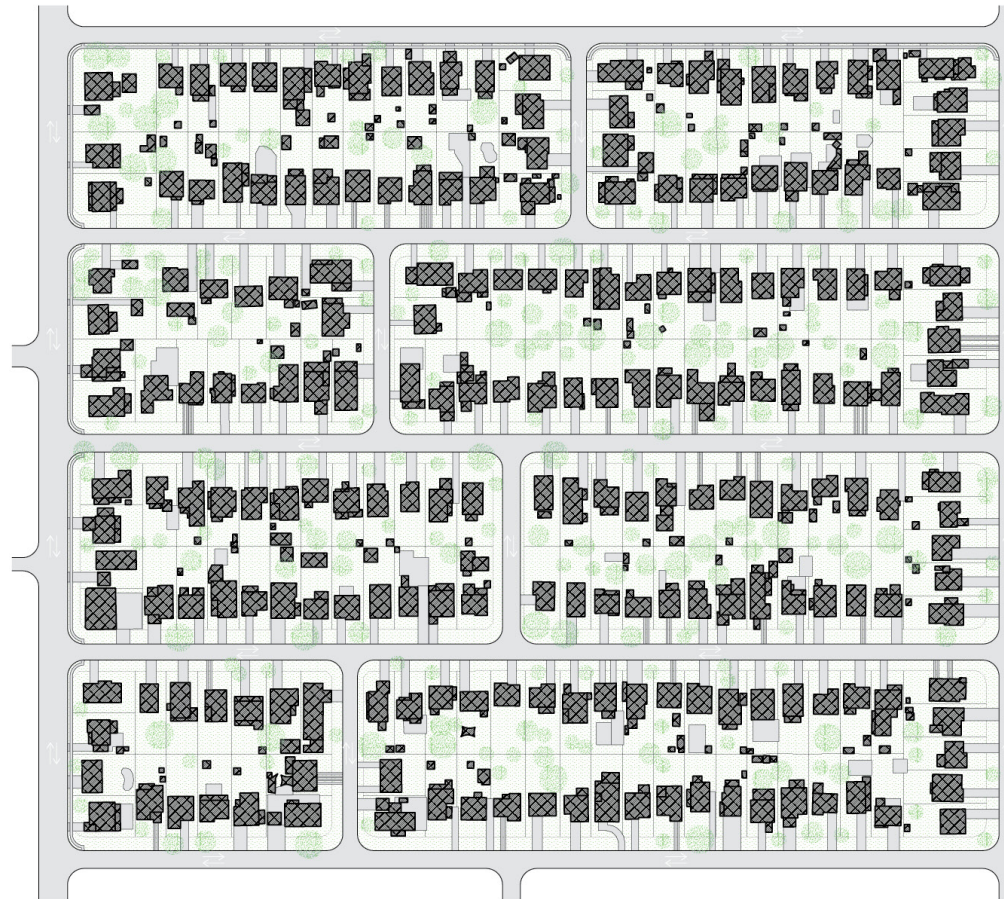



# Example 1, Suburban Housing in Moreton Bay Australia

## Conversion for future AVs

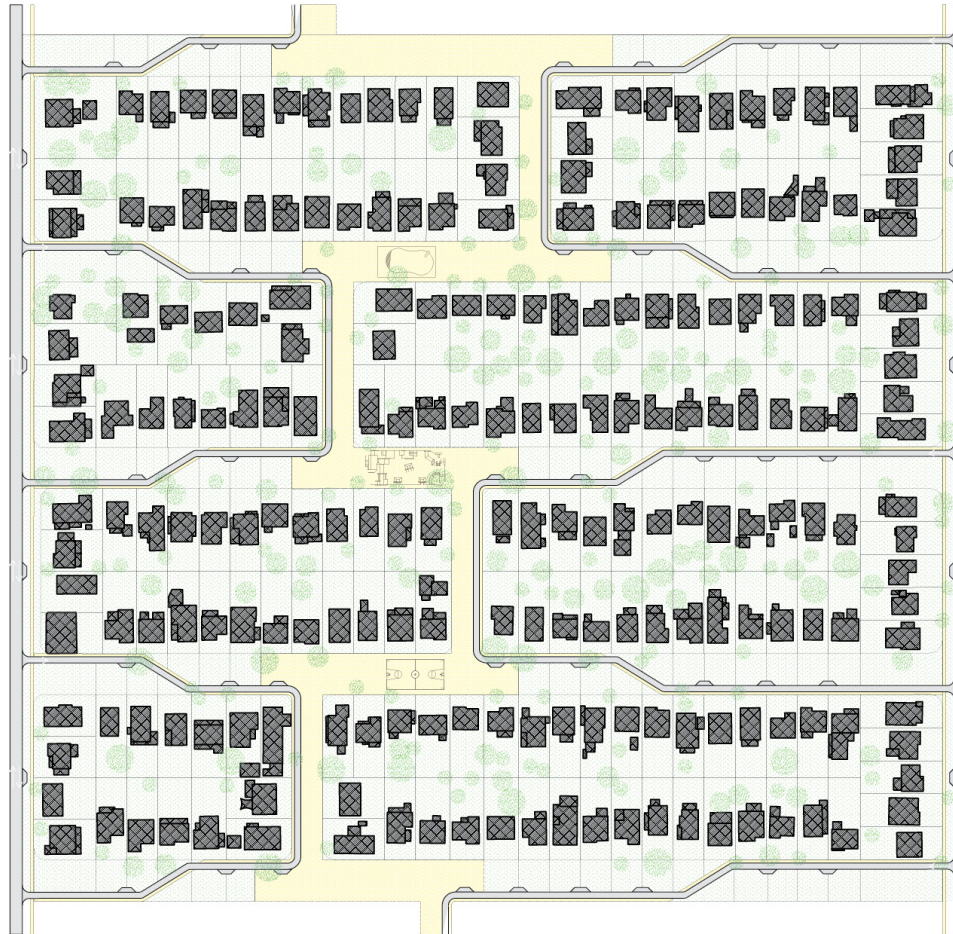

# Example 1, Suburban Housing in Moreton Bay Australia Data

## Existing Layout Data

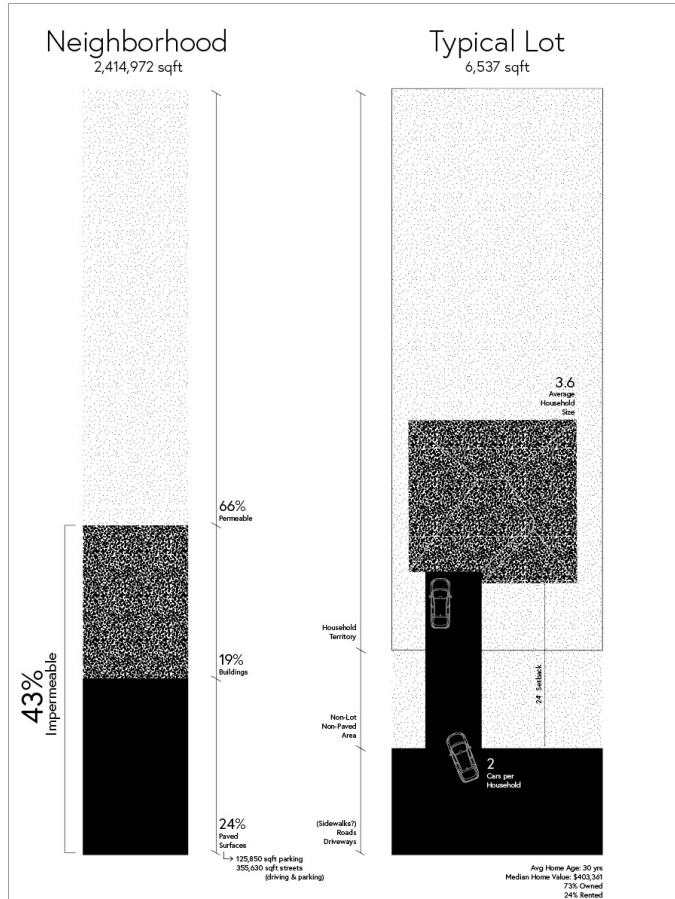

## Proposed Layout Data

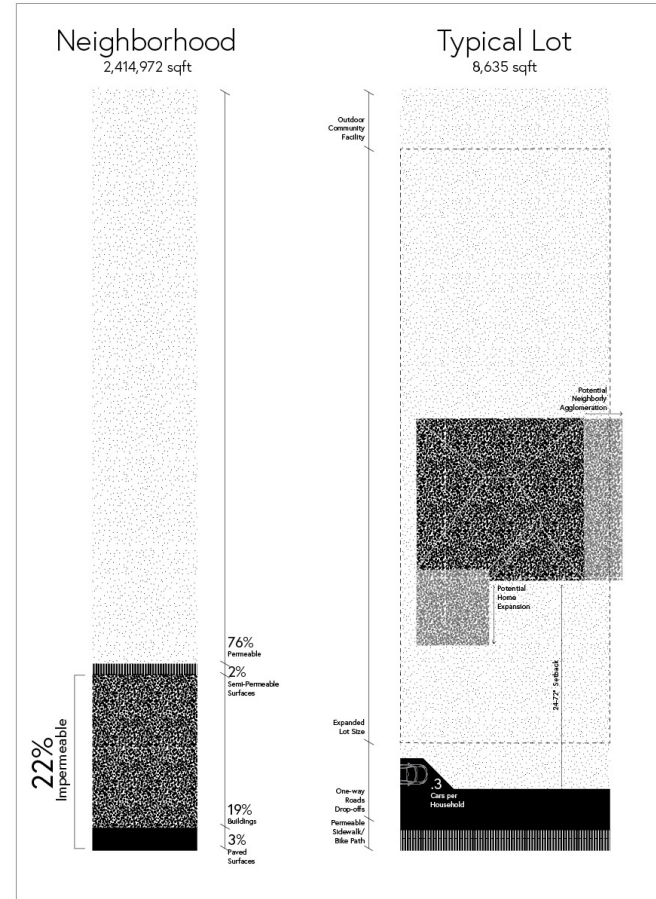



# Example 2, Suburban Center in Moreton Bay Australia Existing Layout

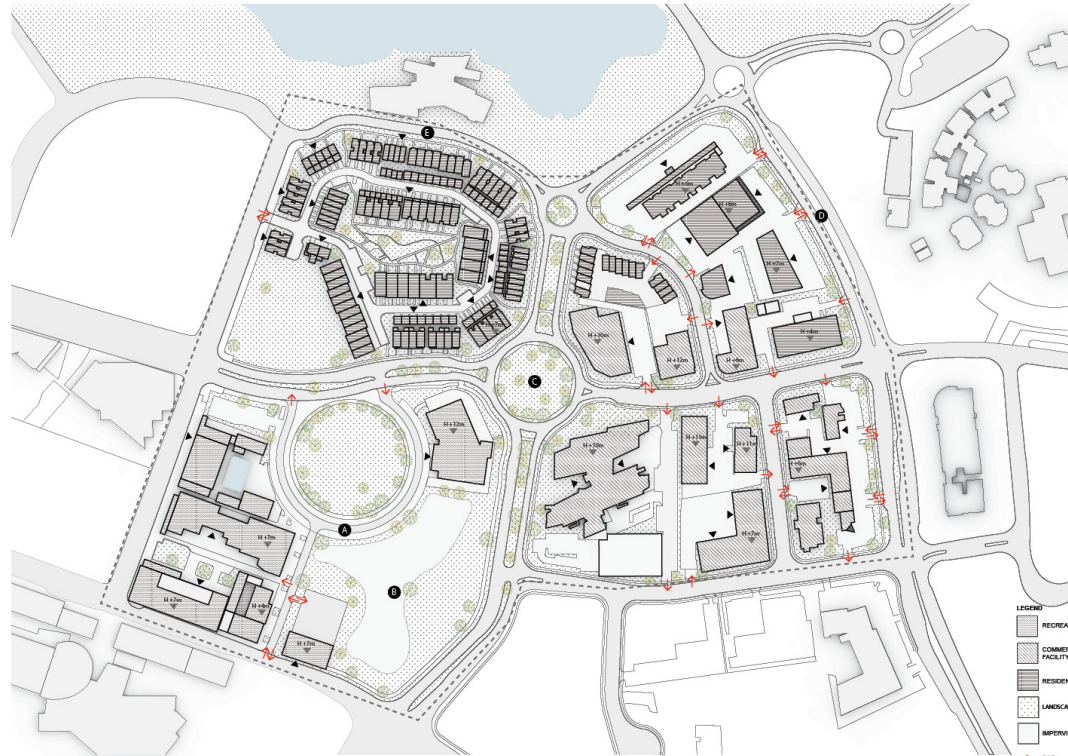

	Total Site Area	Total Building Footprint Area	Open Space Area	Total PerVIOUS Area	Total Impervious Area	Roadway Area	Driveway Area	Parking Area	Vehicle Designated Area (R+D+P)	Lot Parking	Street Parking	Private Garages/Others	Total PerVIOUS Area	Private Area	Public/Shared Area	Public/Shared Area	Programmed Public/Shared Area	Unprogrammed Public/Shared Area
EXISTING	235,694.69	91,763.71	194,276.97	91,262.16	102,817.61	47,866.12	2,026.63	27,096.12	77,799.77	42,997.15	2,130	16,276.14	91,953.16	47,877.94	34,475.22	34,475.22	1,234	34,475.22

**LEGEND**

- RECREATION
- COMMERCIAL FACILITY
- RESIDENTIAL
- LANDSCAPE
- IMPERVIOUS

↑ CAR ENTRANCE  
▲ PEDESTRIAN

0 100m

# Example 2, Suburban Center in Moreton Bay Australia Conversion for future AVs





# Example 2, Suburban Center in Moreton Bay Australia Data

## Existing Layout Data

Avg lot size	6237		
Avg size of building footprint	687.12		
Avg dedicated parking area per building footprint area	3814 m <sup>2</sup>		
Avg set back distance	11.5		
Density (buildings per acre avg)	2.46		
Year of development	2003-2016		
Avg number of employees per acre (estimate)	9.31		
Avg contiguous recreational/open space area	2,315		
	<b>ORIGINAL</b>	<b>PROPOSAL</b>	
Total Site Area	235,684.68	235,684.68	
Total Building Footprint Area	51,313.71	51,313.71	
Open Space Area	184,370.97	184,370.97	
	<b>ORIGINAL</b>	<b>PROPOSAL</b>	
Open Space Area	184,370.97	184,370.97	
Total Pervious Area	81,553.16	130,979.77	<b>60.61%</b>
Total Impervious Area	102,817.81	53,391.2	<b>-48.07%</b>
	<b>ORIGINAL</b>	<b>PROPOSAL</b>	
Total Impervious Area	102,817.81		
Roadway Area	47,866.12	22,279.92	<b>-53.45%</b>
Driveway Area	2,026.53	0	<b>-100.00%</b>
Parking Area	27,896.12	3,424.848	<b>-87.72%</b>
Vehicle Designated Area (R+D+P)	77,788.77	25,704.768	<b>-66.96%</b>
	<b>ORIGINAL</b>	<b>PROPOSAL</b>	
Vehicle Designated Area			
Lot Parking	42,997.15	2,656.7	<b>-93.82%</b>
Street Parking	2,138	768.148	<b>-64.07%</b>
Private Garages/Others	16,275.14	5,786	<b>-64.45%</b>
	<b>ORIGINAL</b>	<b>PROPOSAL</b>	
Total Pervious Area	81,553.16	130,979.77	<b>60.61%</b>
Private Area	47,077.94	52,345	<b>11.19%</b>
Public/Shared Area	34,475.22	78,634.77	<b>128.09%</b>
	<b>ORIGINAL</b>	<b>PROPOSAL</b>	
Public/Shared Area	34,475.22	78,634.77	<b>128.09%</b>
Programmed Public/Shared Area	1,234	5,360	<b>334.36%</b>
Unprogrammed Public/Shared Area	34,475.22	73,274.77	<b>112.54%</b>

2

## Proposed Layout Data

Avg lot size	6237		
Avg size of building footprint	687.12		
Avg dedicated parking area per building footprint area	3814 m <sup>2</sup>		
Avg set back distance	11.5		
Density (buildings per acre avg)	2.46		
Year of development	2003-2016		
Avg number of employees per acre (estimate)	9.31		
Avg contiguous recreational/open space area	2,315		
	<b>ORIGINAL</b>	<b>PROPOSAL</b>	
Total Site Area	235,684.68	235,684.68	
Total Building Footprint Area	51,313.71	51,313.71	
Open Space Area	184,370.97	184,370.97	
	<b>ORIGINAL</b>	<b>PROPOSAL</b>	
Open Space Area	184,370.97	184,370.97	
Total Pervious Area	81,553.16	130,979.77	<b>60.61%</b>
Total Impervious Area	102,817.81	53,391.2	<b>-48.07%</b>
	<b>ORIGINAL</b>	<b>PROPOSAL</b>	
Total Impervious Area	102,817.81		
Roadway Area	47,866.12	22,279.92	<b>-53.45%</b>
Driveway Area	2,026.53	0	<b>-100.00%</b>
Parking Area	27,896.12	3,424.848	<b>-87.72%</b>
Vehicle Designated Area (R+D+P)	77,788.77	25,704.768	<b>-66.96%</b>
	<b>ORIGINAL</b>	<b>PROPOSAL</b>	
Vehicle Designated Area			
Lot Parking	42,997.15	2,656.7	<b>-93.82%</b>
Street Parking	2,138	768.148	<b>-64.07%</b>
Private Garages/Others	16,275.14	5,786	<b>-64.45%</b>
	<b>ORIGINAL</b>	<b>PROPOSAL</b>	
Total Pervious Area	81,553.16	130,979.77	<b>60.61%</b>
Private Area	47,077.94	52,345	<b>11.19%</b>
Public/Shared Area	34,475.22	78,634.77	<b>128.09%</b>
	<b>ORIGINAL</b>	<b>PROPOSAL</b>	
Public/Shared Area	34,475.22	78,634.77	<b>128.09%</b>
Programmed Public/Shared Area	1,234	5,360	<b>334.36%</b>
Unprogrammed Public/Shared Area	34,475.22	73,274.77	<b>112.54%</b>

2







# Example 3, Suburban Housing in Palm Springs, CA Existing Layout



## Silvermist Development

Company: K. Hovnanian Homes  
 Type: Single Family Homes  
 House Size: 2,787-4,002 sqft  
 Price: \$1,000,000

Building Footprint to Open Space

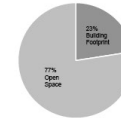

Pervious and Impervious Surfaces

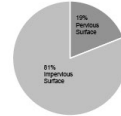

Vehicular Surfaces

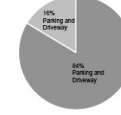

Private and Shared Open Spaces

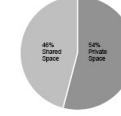

# Example 3, Suburban Housing in Palm Springs, CA

## Conversion for future AVs

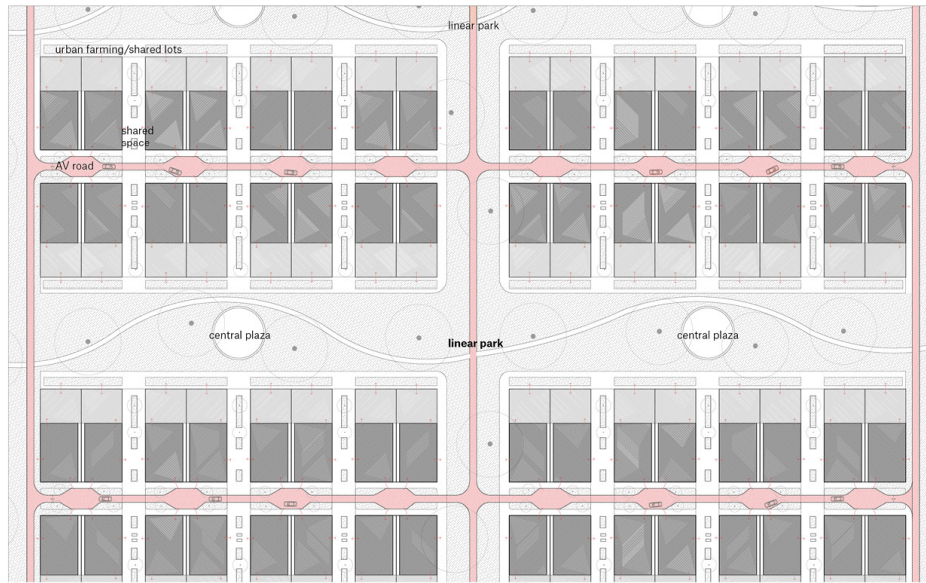

### Building Typology Development

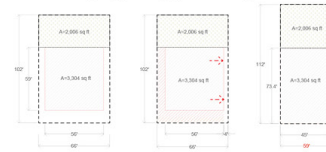

**%48 Reduction of impervious surface**  
**0.51 FAR**  
**0.25 COV**

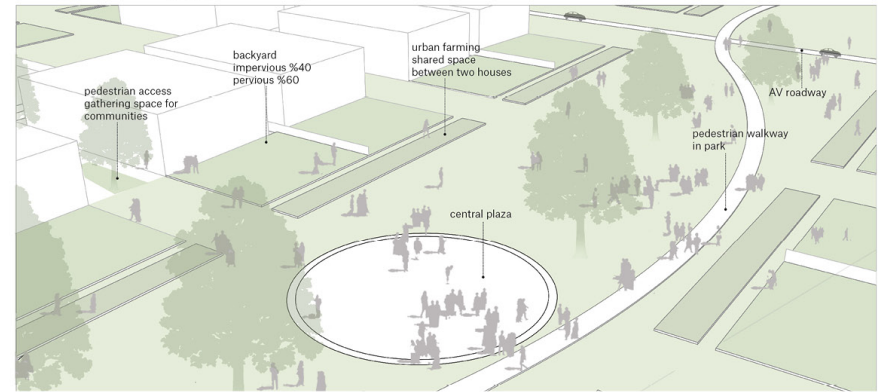



# Example 4, Suburban Housing in Palm Springs, CA

## Existing Layout

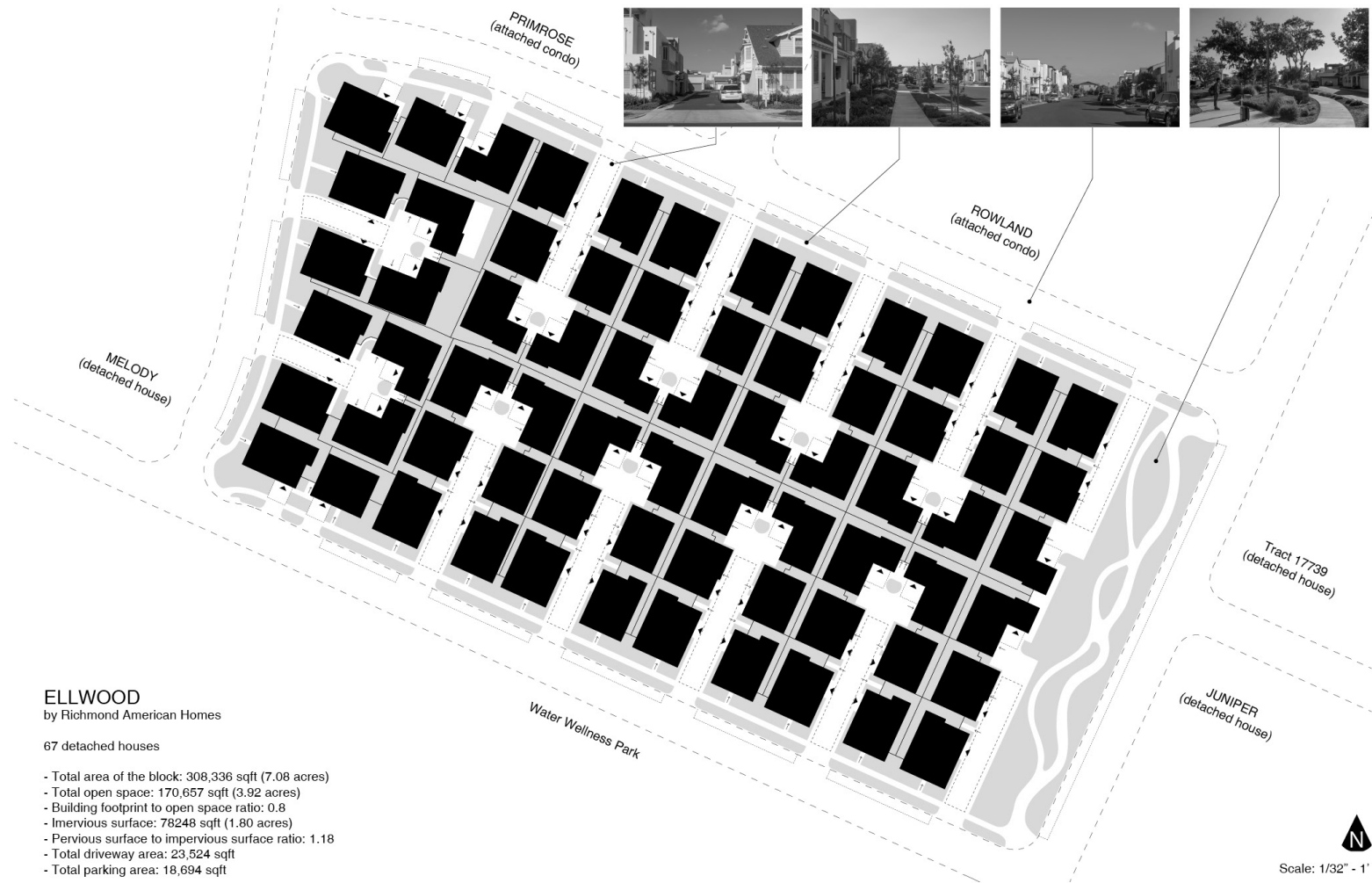

# Example 4, Suburban Housing in Palm Springs, CA

## Conversion for future AVs

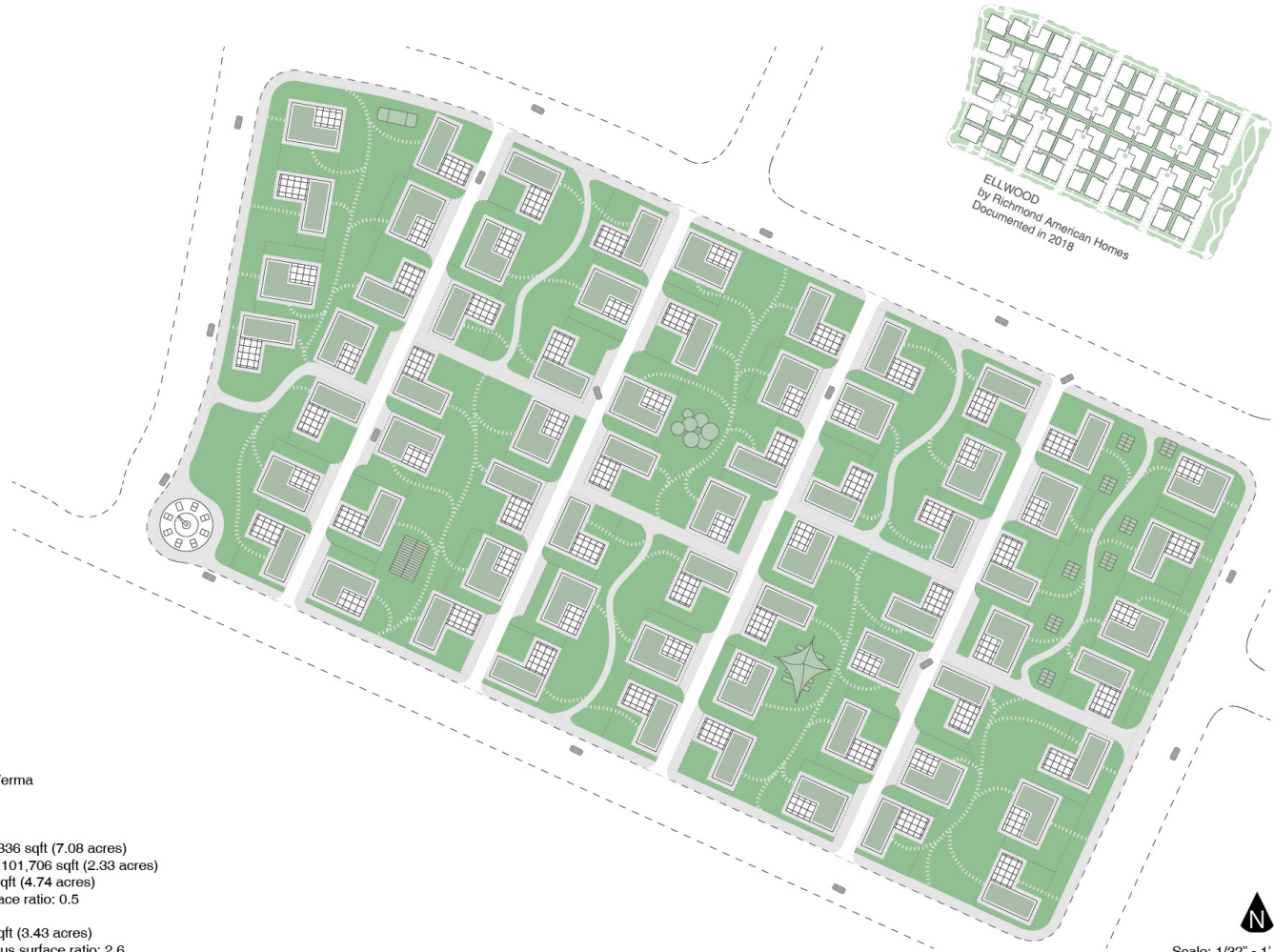
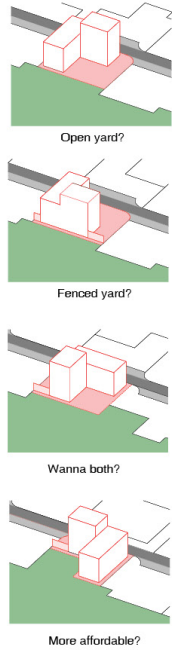

### ELLWOOD 2050

by Haoyu Wang and Piyush Verma

67 detached houses

- Total area of the block: 308,336 sqft (7.08 acres)
- Total building footprint area: 101,706 sqft (2.33 acres)
- Total open space: 206,630 sqft (4.74 acres)
- Building footprint to open space ratio: 0.5

- Pervious surface: 149,553 sqft (3.43 acres)
- Pervious surface to impervious surface ratio: 2.6



***REGION***  
***ENVIRONMENT***

The image is a vertical collage of various coastal and urban scenes. At the top, there's a city skyline at sunset or sunrise, with buildings silhouetted against a warm, orange sky. Below this, a large body of water is shown, possibly a harbor or bay, with several boats and a prominent bridge structure on the right side. The bridge has a large, angled steel truss section. In the foreground, there are lush green wetlands with tall grasses and reeds. A white egret is visible in the lower right, standing in the shallow water. The overall color palette is dominated by greens, blues, and warm sunset tones. The text 'BIGHT: COASTAL URBANISM' is centered in a bold, white, sans-serif font with a black outline.

# **BIGHT: COASTAL URBANISM**





The Bight region is in a severe crisis

Storm surges are becoming a common picture

0 5 10 20 Miles













1929

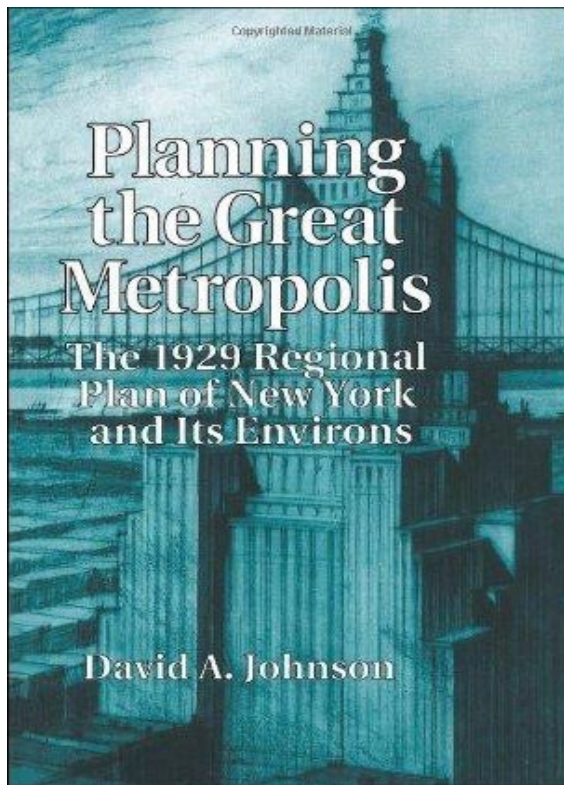

## The First Regional Plan (1929)





2017



The Fourth Regional Plan | Regional Plan Association

**R P A** Regional Plan Association

Subscribe Donate

Search our site ...

WHO WE ARE WHAT WE DO WHERE WE WORK PUBLICATIONS NEWSROOM EVENTS CONTACT

## The Fourth Regional Plan

**A Region Transformed**

*RPA is crafting a long-range vision for the region's shared prosperity, health and livability, resiliency and good governance. The Fourth Regional Plan, due in 2017, will propose investments and policies to ensure the region's success for all residents.*

The banner features a dark background with several colorful geometric shapes: a large blue circle at the top left, a green triangle at the bottom left, and an orange square in the center. There are also three blue circles at the bottom right. The text 'A Region Transformed' is written in a large, white, sans-serif font. Below the banner, there is a paragraph of text in a smaller, italicized font.

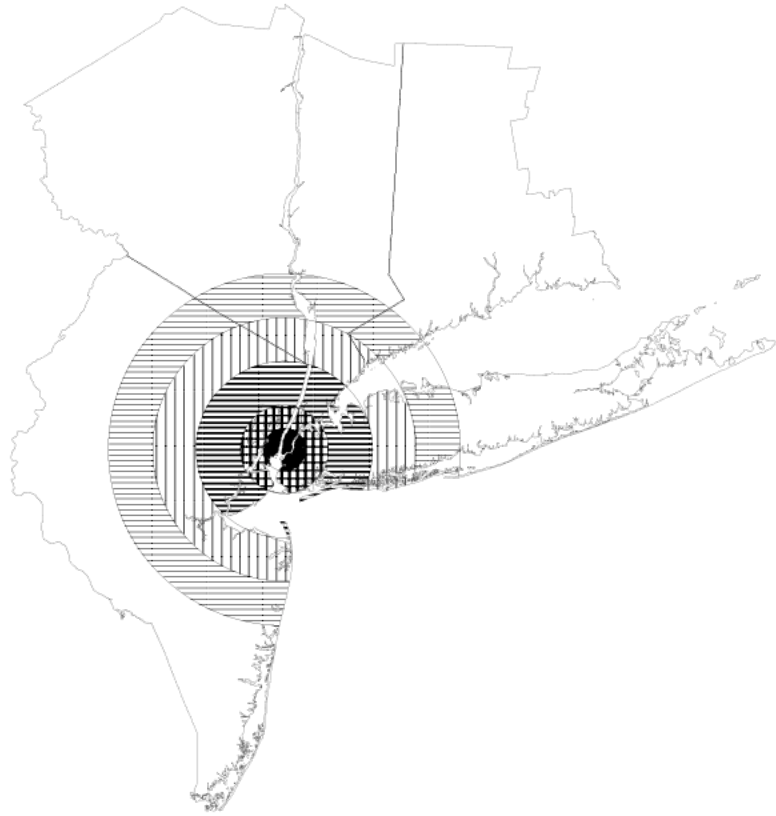

**1<sup>ST</sup> REGIONAL PLAN 1929  
CONCENTRIC RINGS**

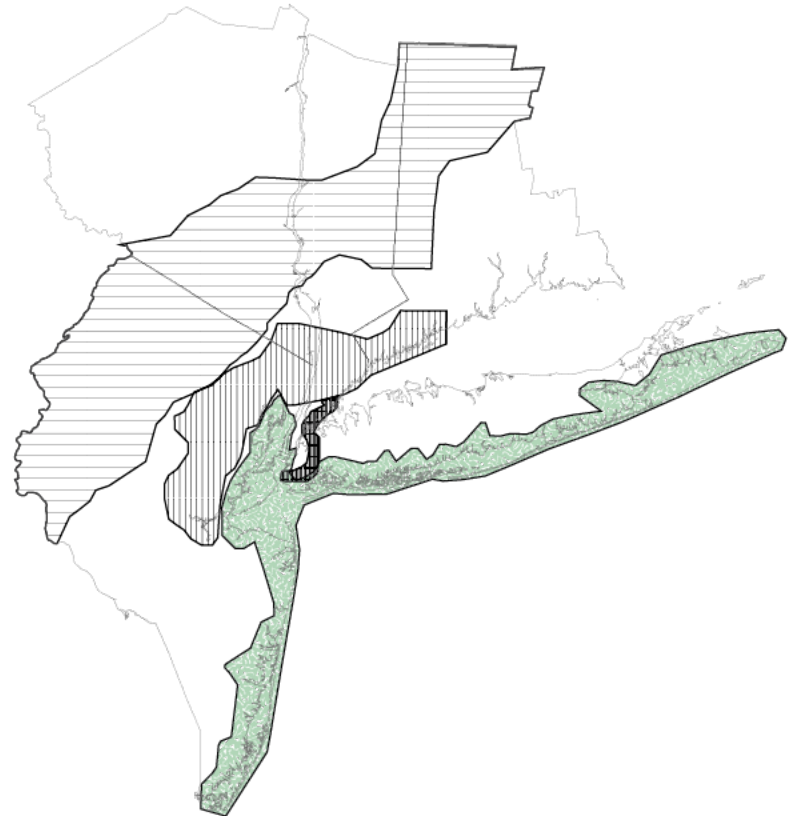

**4<sup>TH</sup> REGIONAL PLAN, 2017  
CORRIDORS**





EARLY HUMAN

# NATURAL EXCHANGE

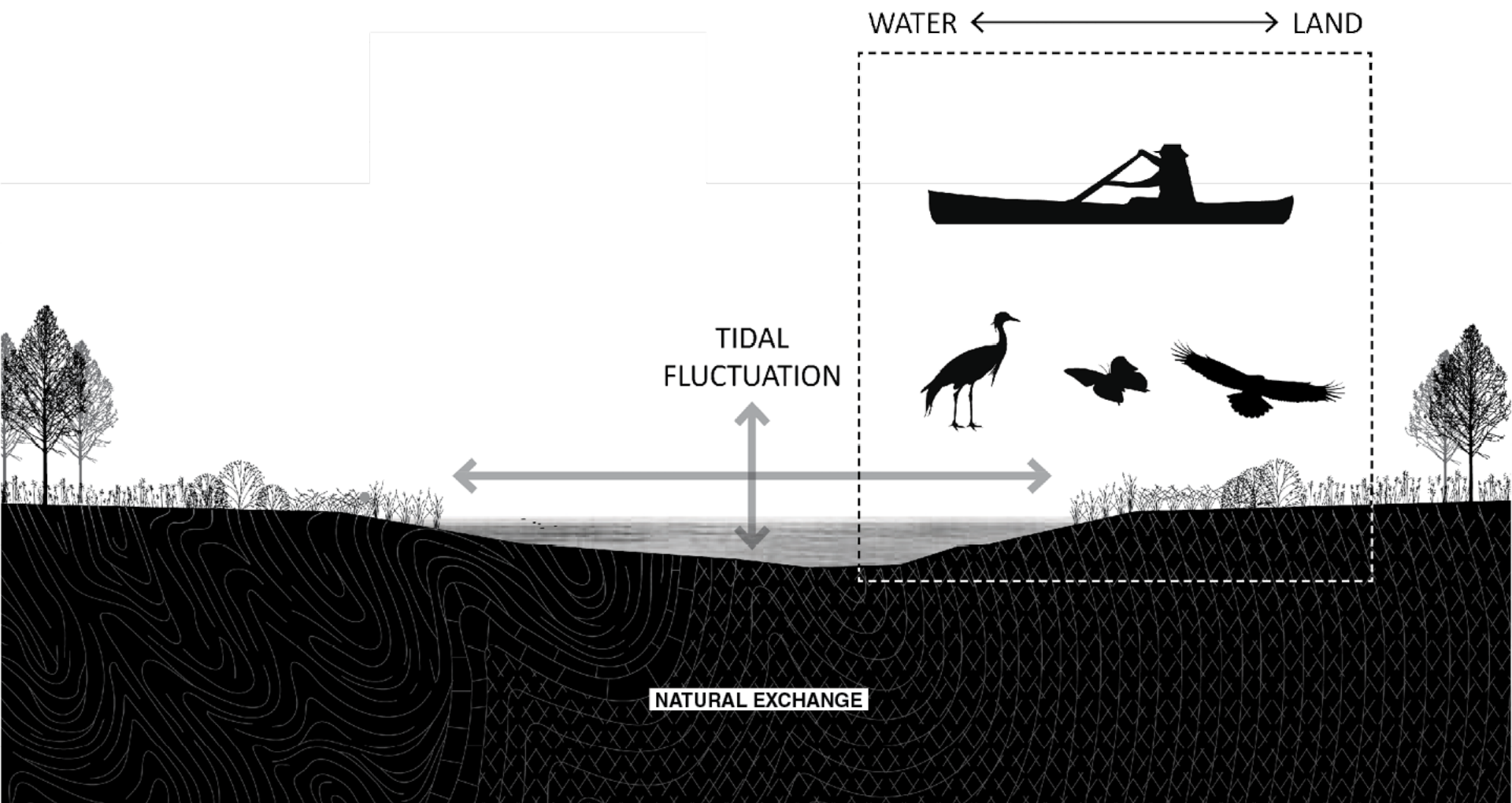



en de Engelfche  
**VIRGINIES**

Van Cabo Col tot Cabo Carriac



CHARTING THE COASTLINE





NEW YORK 1700S



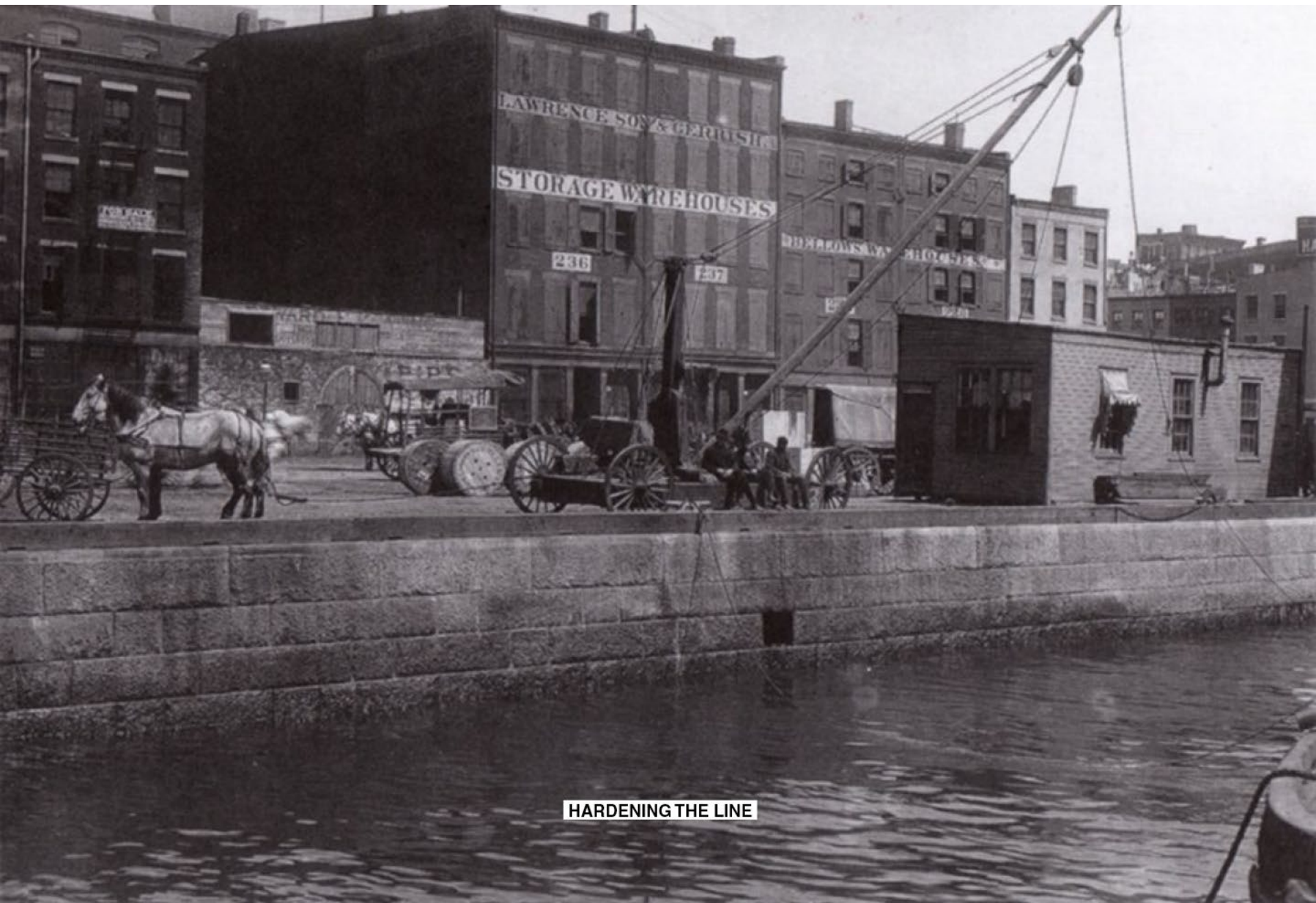

HARDENING THE LINE

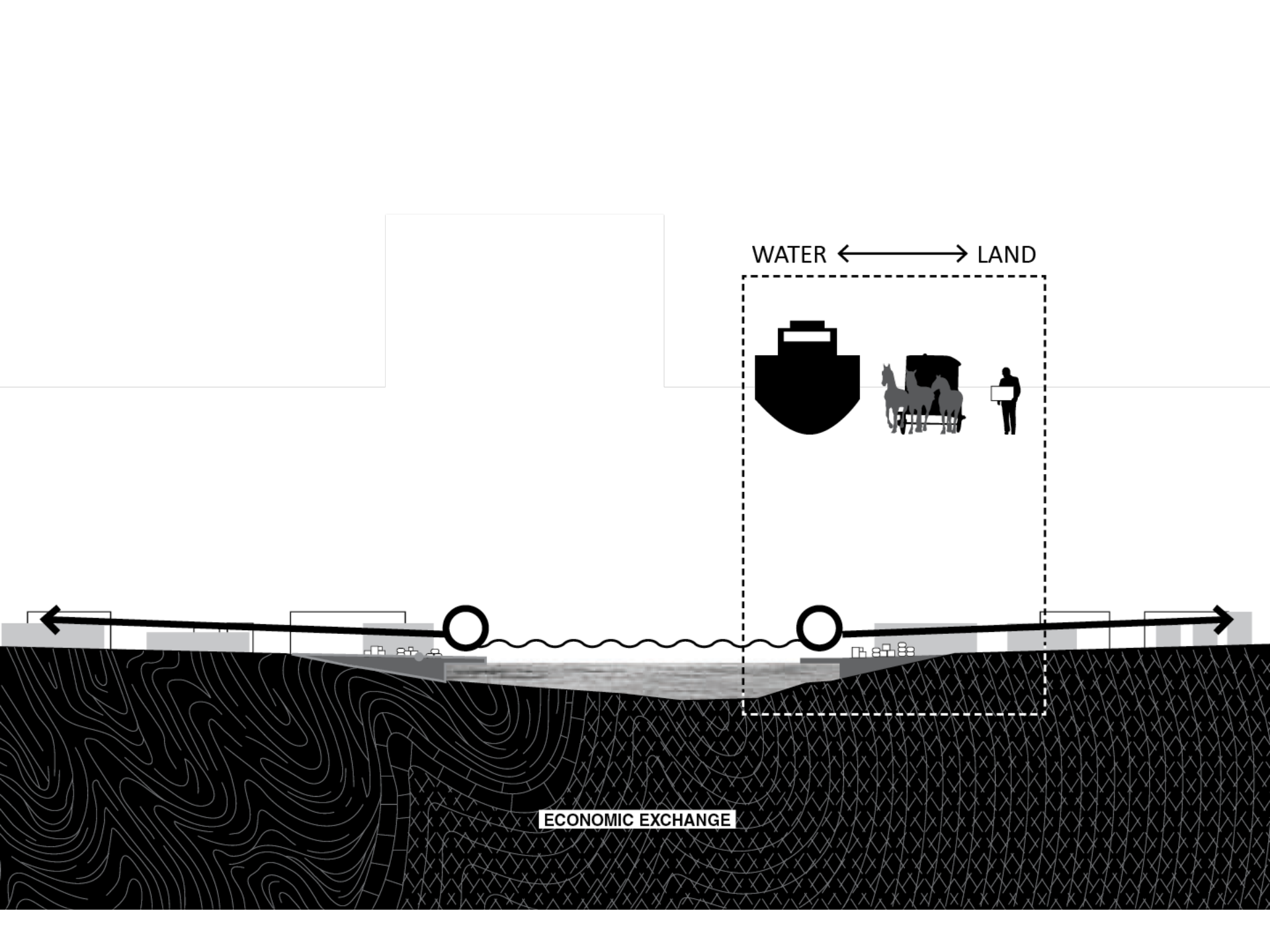









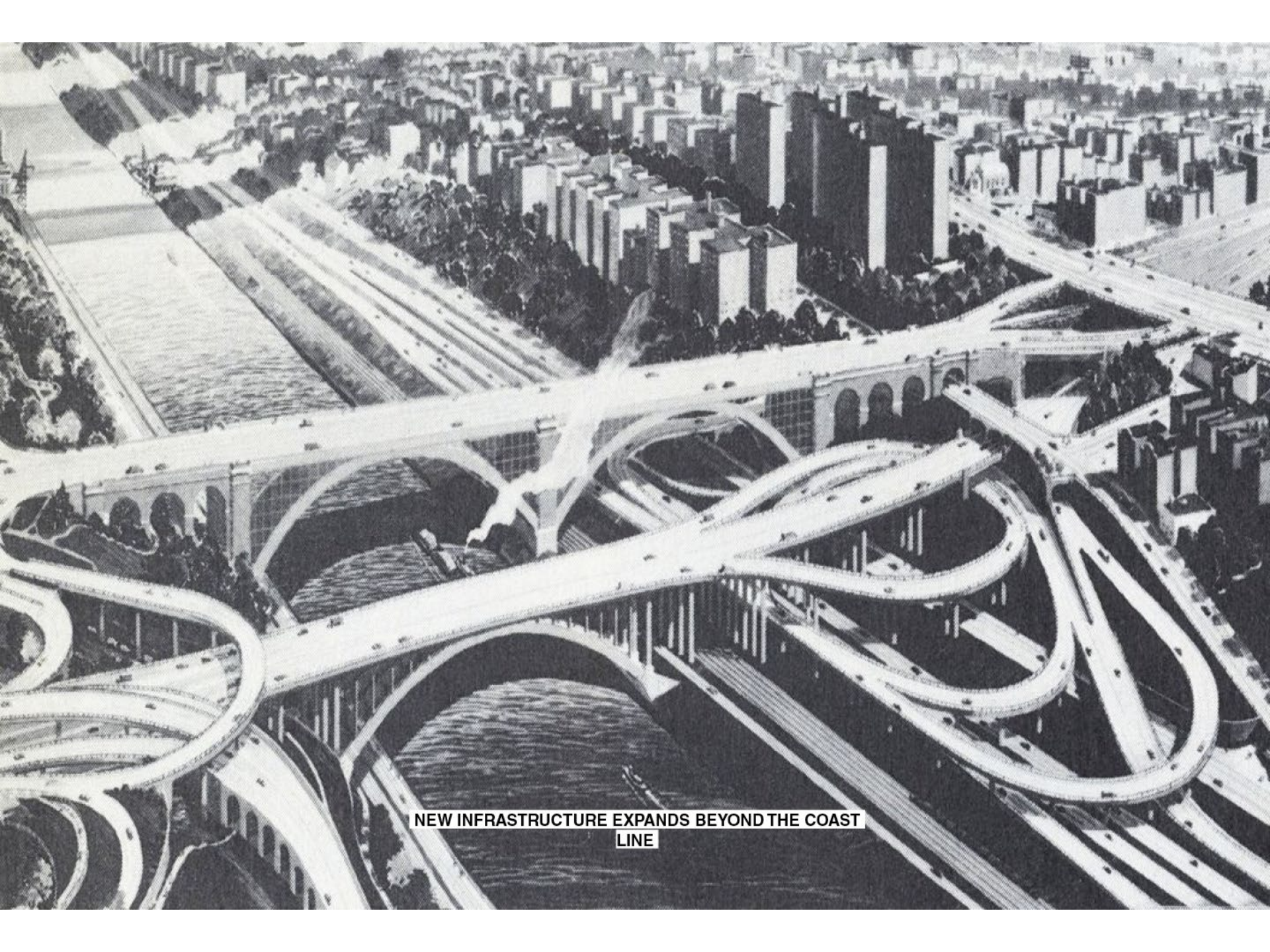

NEW INFRASTRUCTURE EXPANDS BEYOND THE COAST  
LINE



# FRACTURED EXCHANGE

SMALL GROUP OR INDIVIDUAL TRANSPORTATION



HORSE



AUTOMOTIVE



GROUP TRANSPORTATION



HORSE

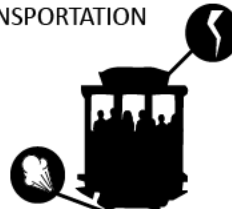

STEAM TO ELECTRIC



AUTOMOTIVE

LONGER DISTANCE TRANSPORTATION

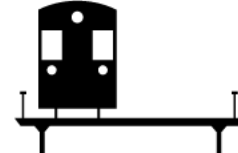

ELEVATED



UNDERGROUND

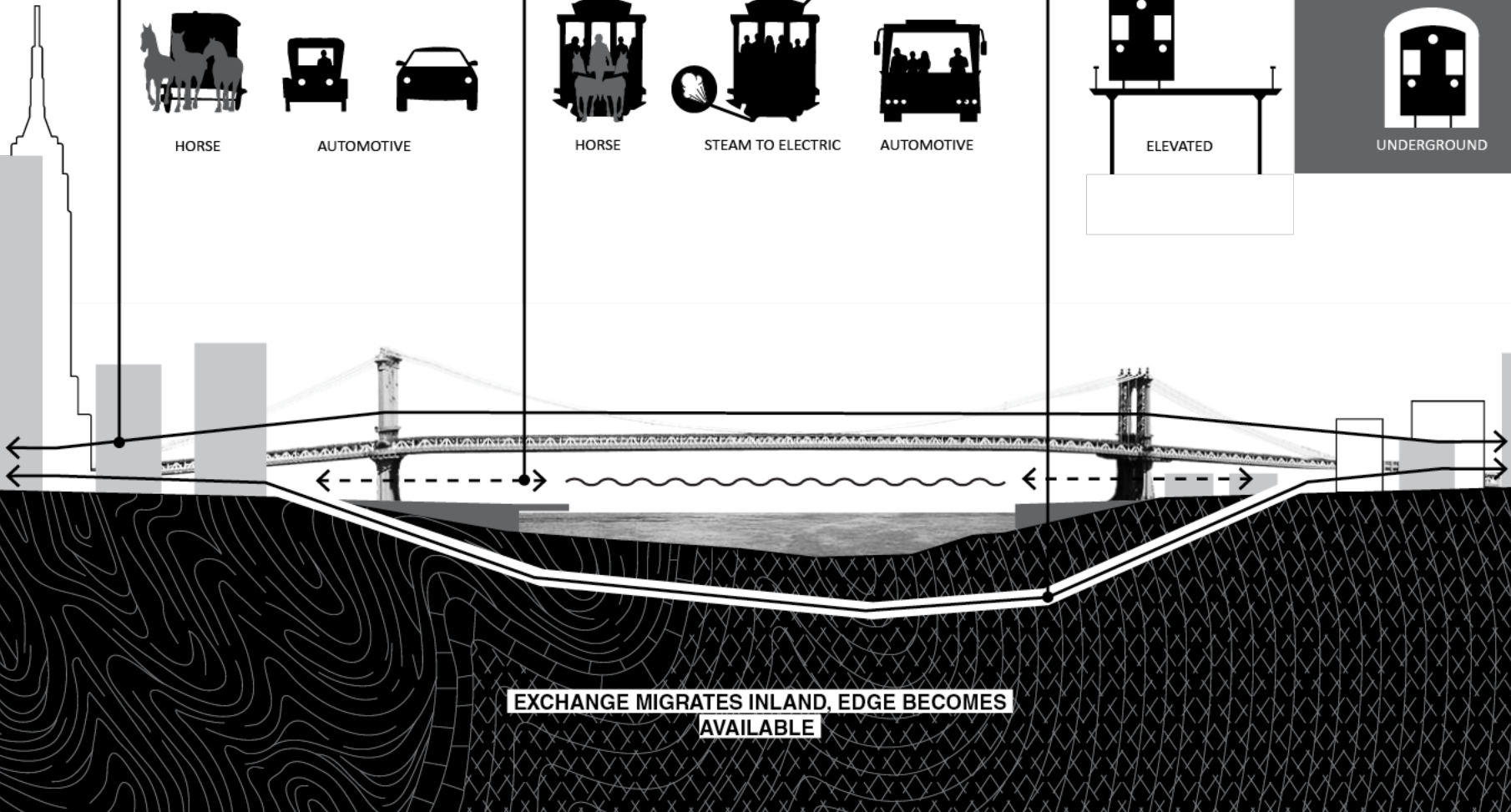

EXCHANGE MIGRATES INLAND, EDGE BECOMES AVAILABLE







MASS RECREATION ALONG THE COAST





20TH CENTURY LEISURE

SHORPY



PUBLIC HOUSING









PRESSURE ON THE LINE



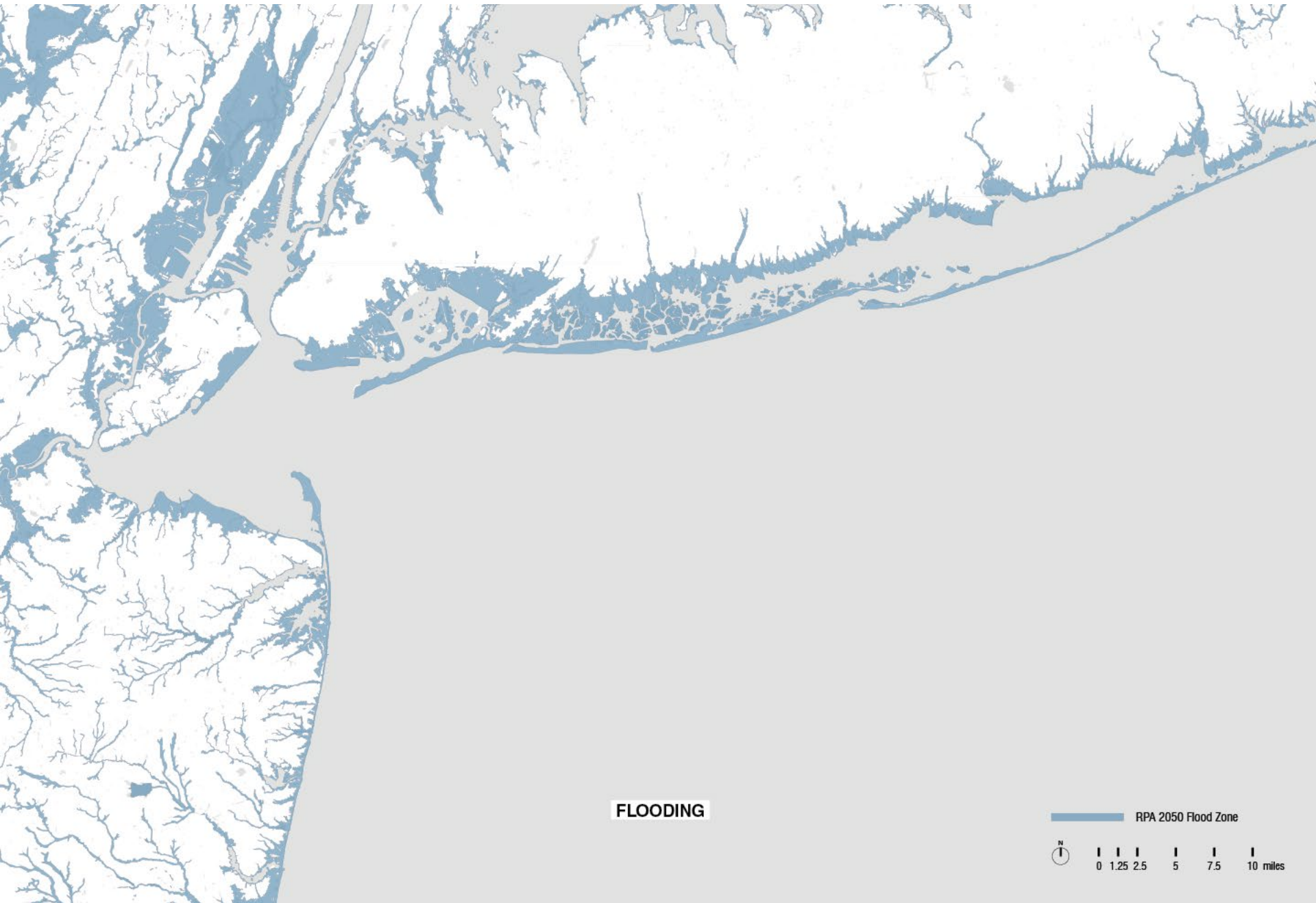

**FLOODING**

RPA 2050 Flood Zone



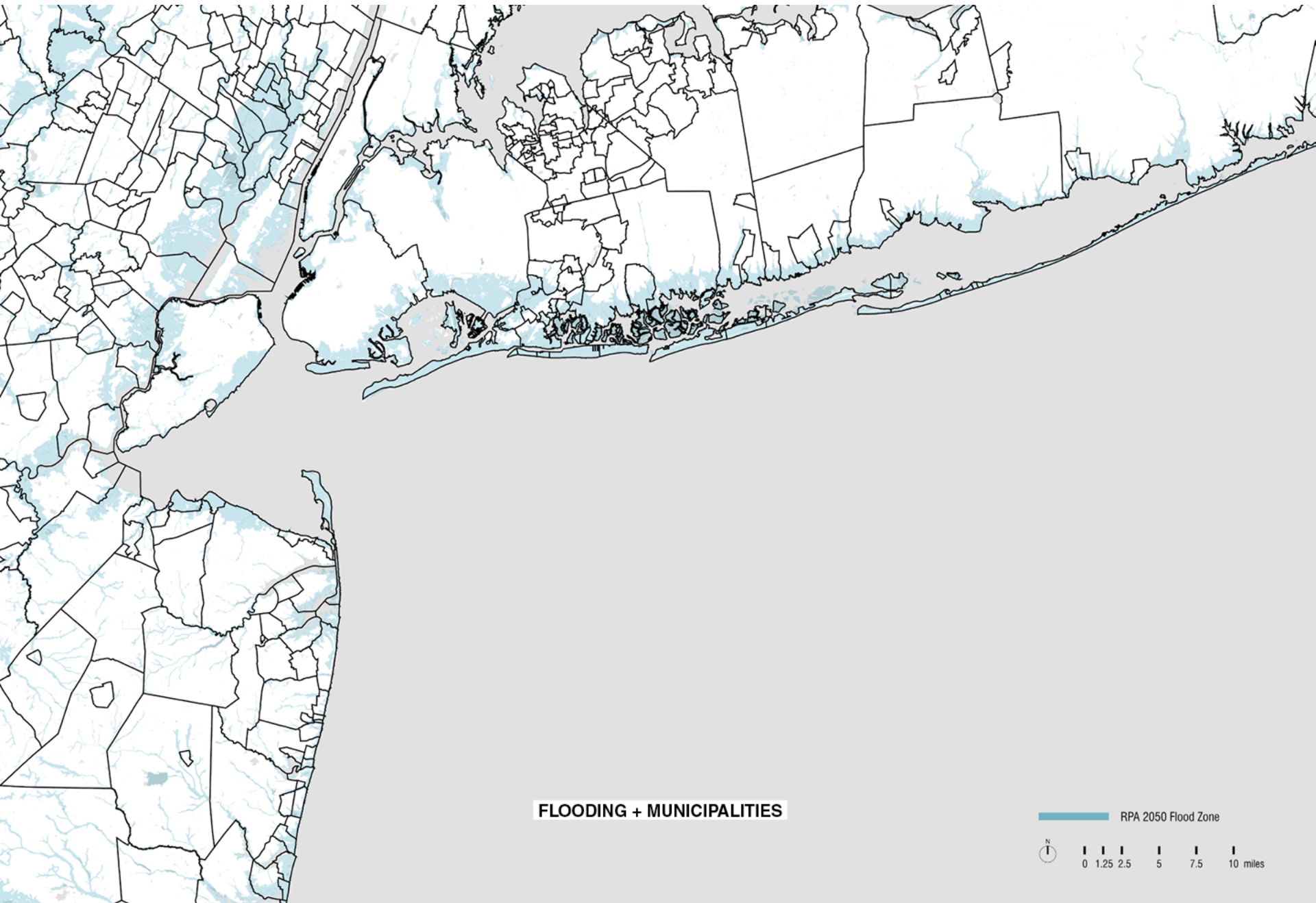

**FLOODING + MUNICIPALITIES**







**BIGHT MUNICIPALITIES**  
**BY PERCENTAGE OF FLOOD HAZARD AREA**



**NEW JERSEY:**  
**\$ 8,240,232,000**

**NEW YORK:**  
**\$ 11,919,891,000**

**AFFECTED BY 2012 HURRICANE SANDY**

**COST OF LOSS**

- Affected sites
- Destroyed sites
- Major sites
- Minor sites





**US**

**NEW  
JERSEY**

**NEW  
YORK**

**72 DIRECT  
DEATHS, 87  
INDIRECT  
DEATHS**

**12 DEATHS**

**48 DEATHS  
ASSOCIATED WITH  
SANDY (HIGHEST  
OF US STATES)**



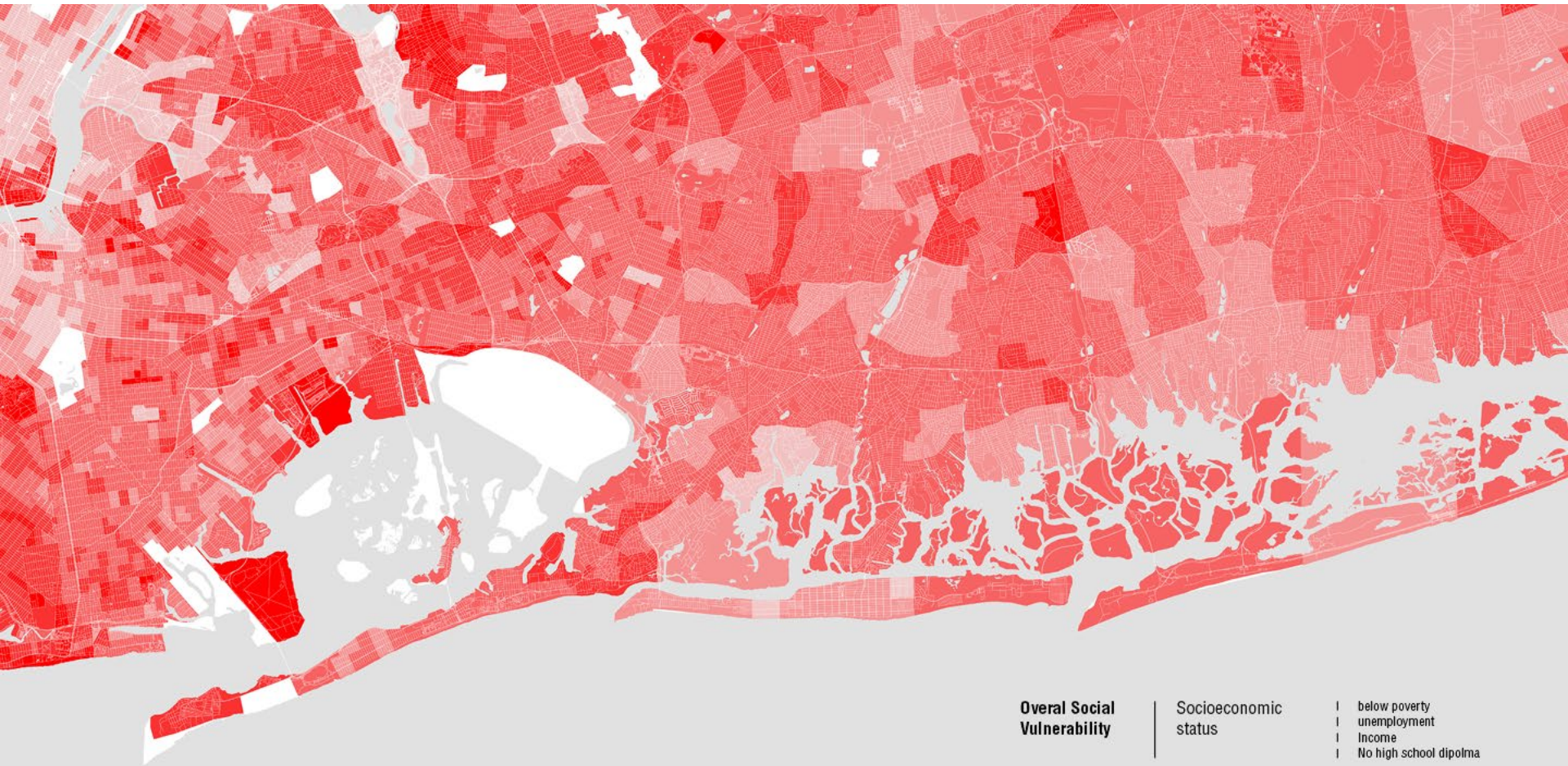

**SOCIAL VULNERABILITY**

**Overall Social Vulnerability**

Socioeconomic status

- | below poverty
- | unemployment
- | Income
- | No high school diploma

Household Composition & Disability

- | Aged 65 or Older
- | Aged 17 or Younger
- | Civilian with disability
- | Single-parent Households

Minority status & Language

- | Minority
- | Speaks English "less than well"

Housing & transportation



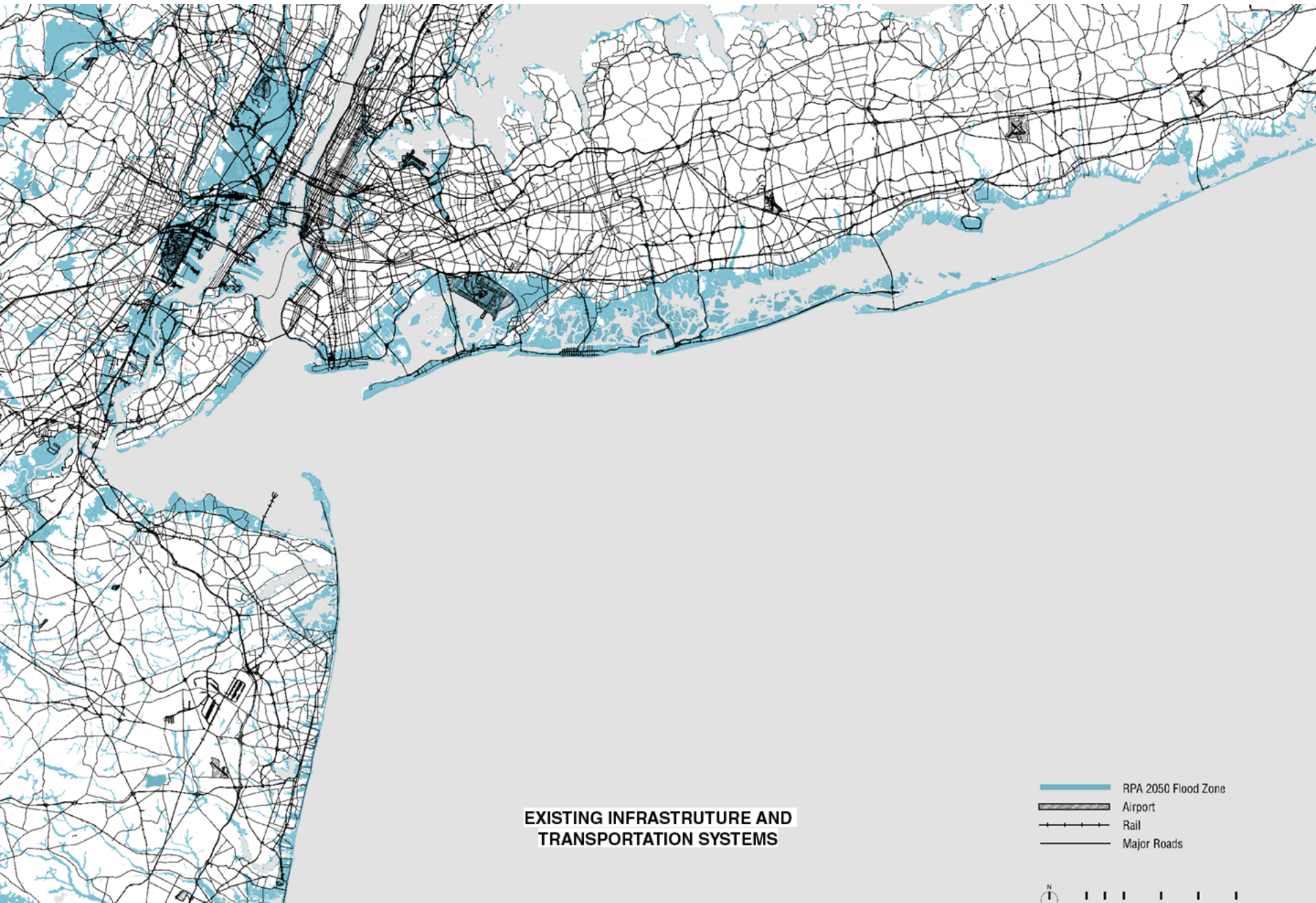

- | Multi-unit structures
- | Mobile homes
- | Crowding
- | No Vehicle
- | Group Quarters

Variables used to derive the Social Vulnerability Index





**EXISTING INFRASTRUTURE AND  
TRANSPORTATION SYSTEMS**



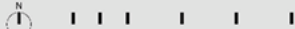

-  RPA 2050 Flood Zone
-  Airport
-  Rail
-  Major Roads





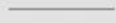

**DAMAGED INFRASTRUCTURE  
FOLLOWING SEA LEVEL RISE**

-  Impacted Airport
-  Major Airport
-  Impacted Rail
-  Major Rail
-  Impacted Roads
-  Major Roads

N





**LAND**

**WATER**

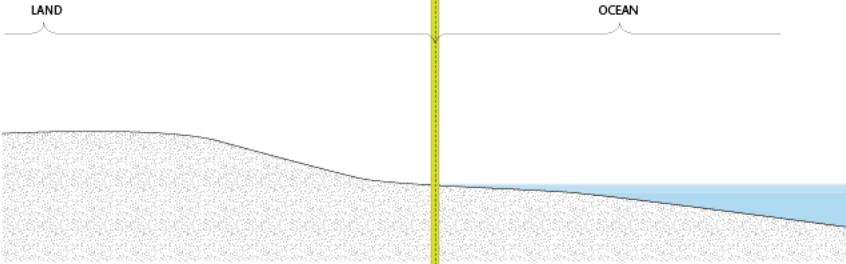

MUNICIPAL JURISDICTION

2017

LAND

WATER

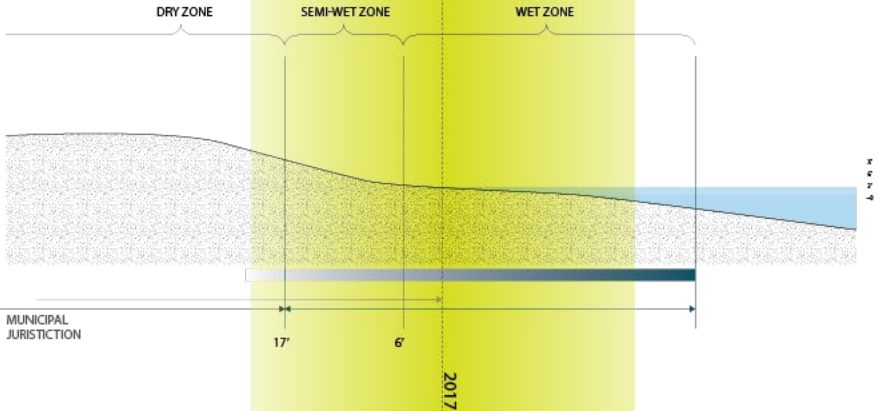

Pressure on the line dividing land and water is released through a zone of protection and exchange. The terrestrial edge becomes a more malleable zone with new economic, cultural and environmental value. We propose to manage this resource with a governing authority we call the Bureau of Coastal Management (BCM). Like the Federal Bureau of Land Management, the BCM would help activate recreation, energy production, agriculture, education and research. The BCM would link with the NPS to extend and connect the open space opportunities across the Bight and into the Meadowlands.





**RECEIVE**

STRENGTHEN EXISTING  
HIGHER GROUND SPINES

**PROTECT**

LANDSCAPE BUFFER

**ADAPT**

URBANISM AND  
LANDSCAPE

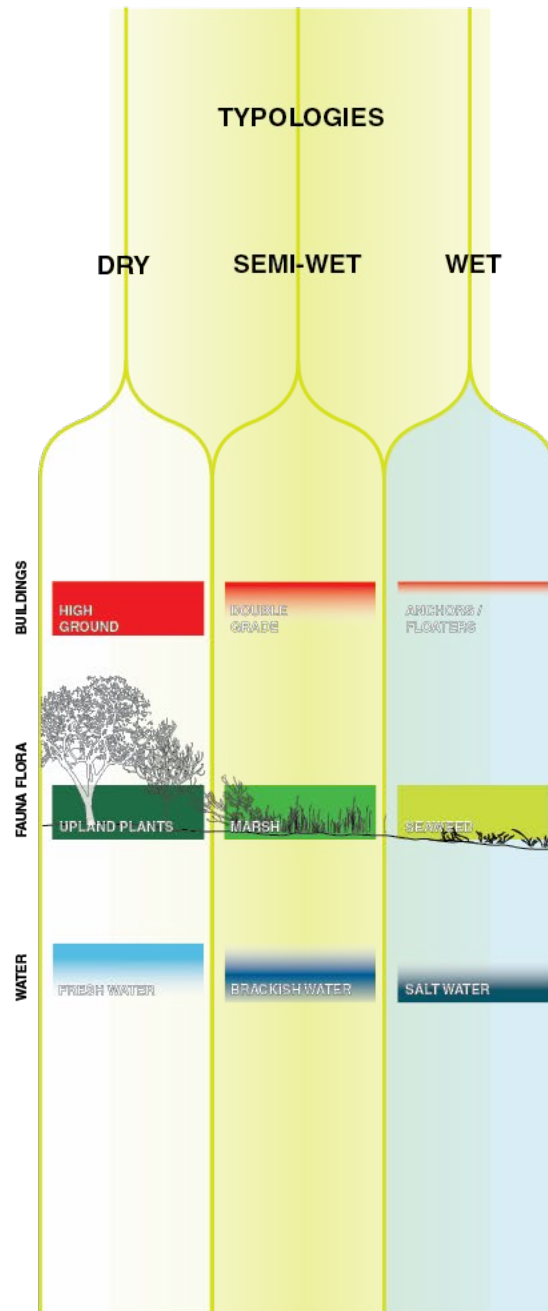





RECREATION



ENERGY FARMING



ECOLOGICAL REGENERATION



CONSERVATION



PROGRAMS AND HABITATION



**ENERGY:**

From centralized petrol based to de-centralized renewable

**RECREATION:**

From large scale seasonal destinations for the masses to smaller scale everyday

**CONSERVATION:**

From passive preservation to active regeneration

**HABITATION:**

Diversifying typologies for a more heterogeneous population and household structures.

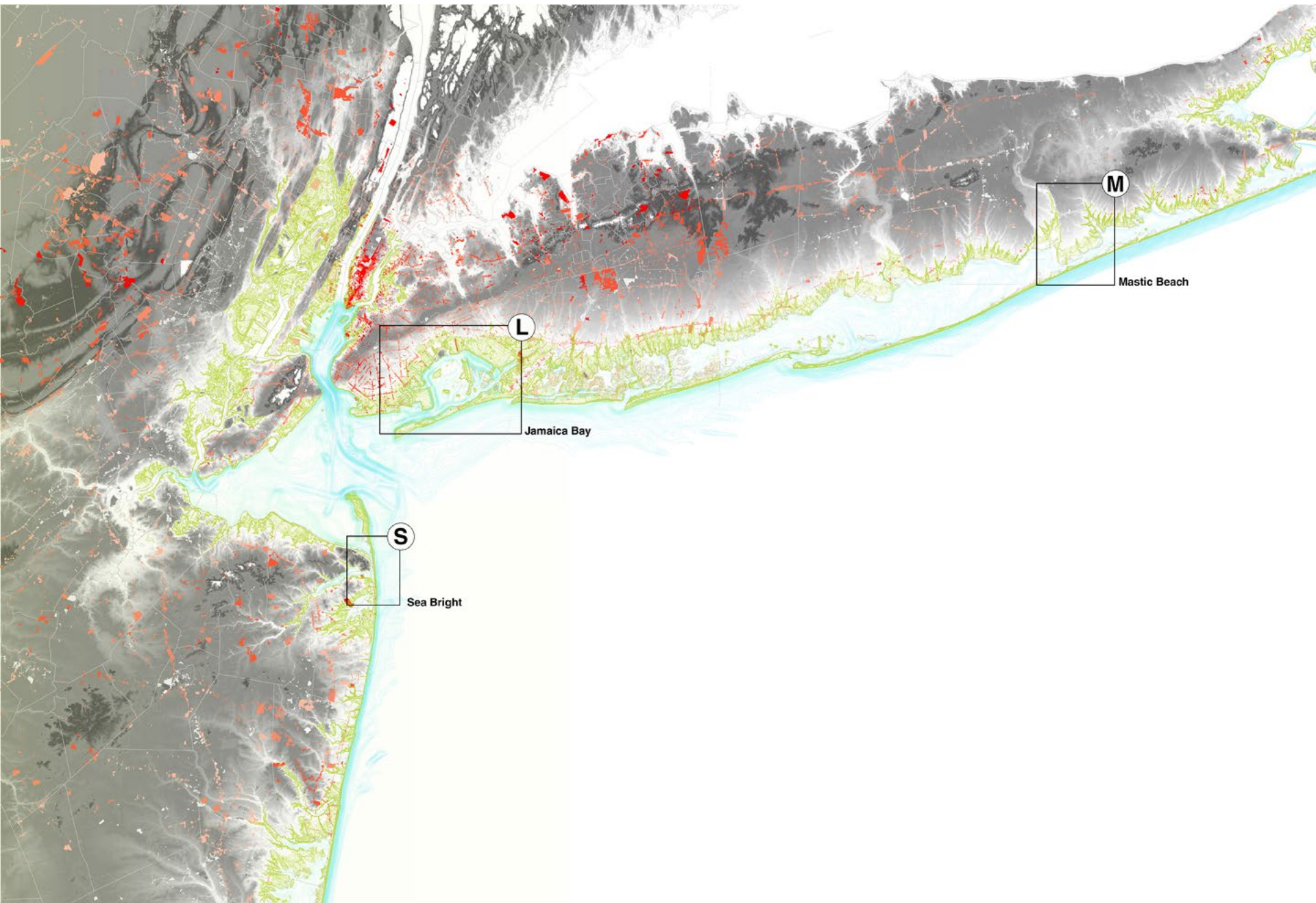

L

Jamaica Bay

M

Mastic Beach

S

Sea Bright



**M**

**MASTIC  
BEACH**







MASTIC CULTURE



# NEW MASTIC 2050

CORRESPONDENCE RECOVERED FROM [NAME REDACTED],  
MASTIC BEACH

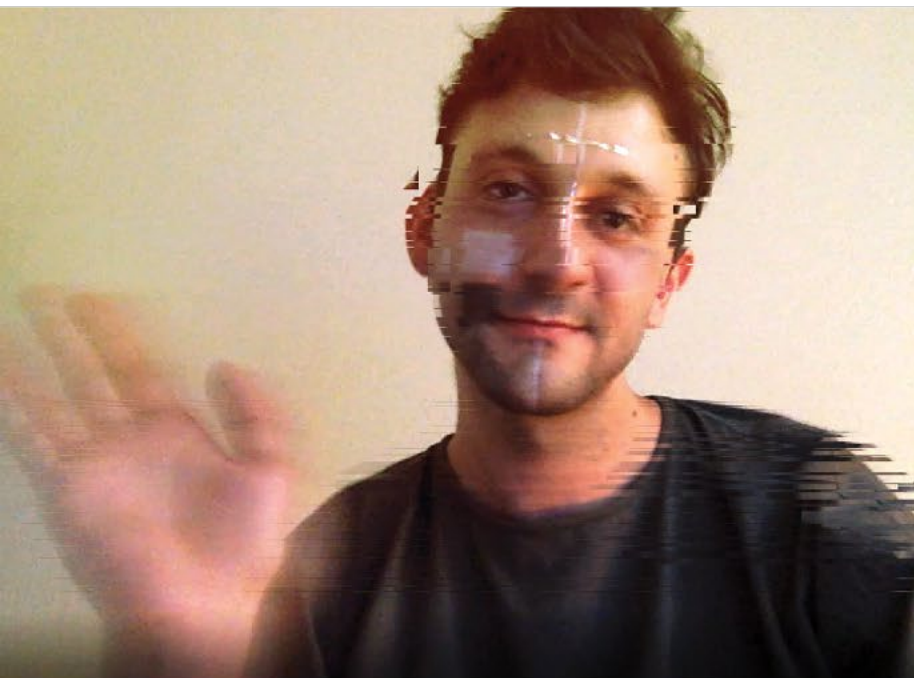

“

Hey sis. . . it's me. Happy birthday. I know we haven't talked in a while, but it's 5:30 here, and I didn't want to wake you.

Up early because Dark Tides says there's a Level 5 Flood coming in today, which means this place will be underwater, which means I have to pack up my stuff and send it up to mom's for the night. Not that I have a lot of stuff, but still.

Speaking of mom, she's good — waiting hand and foot on all these elderly Chinese ladies, making sure they eat their vegetables and asking their smart toilets to ping her if their blood sugar's low.

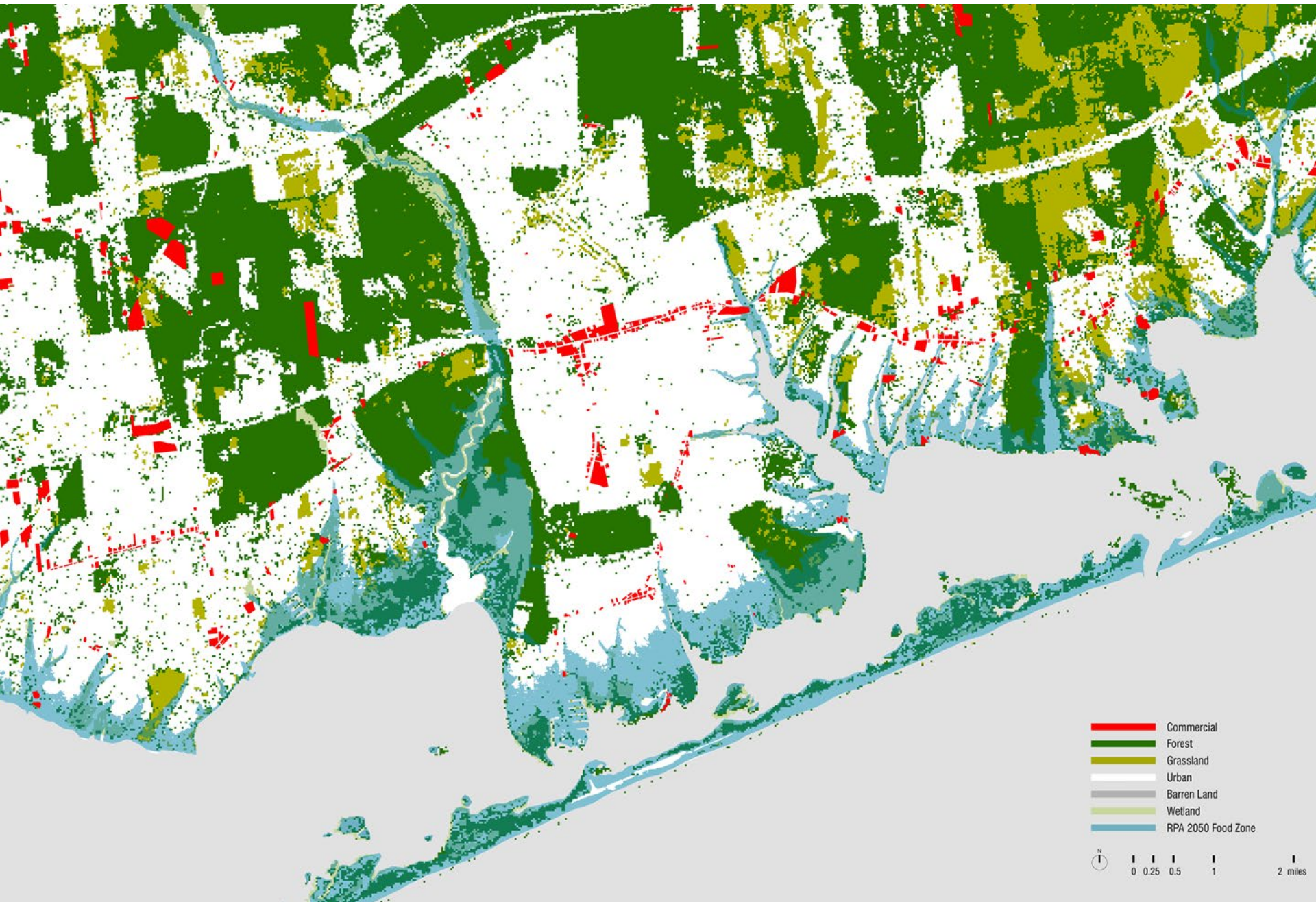



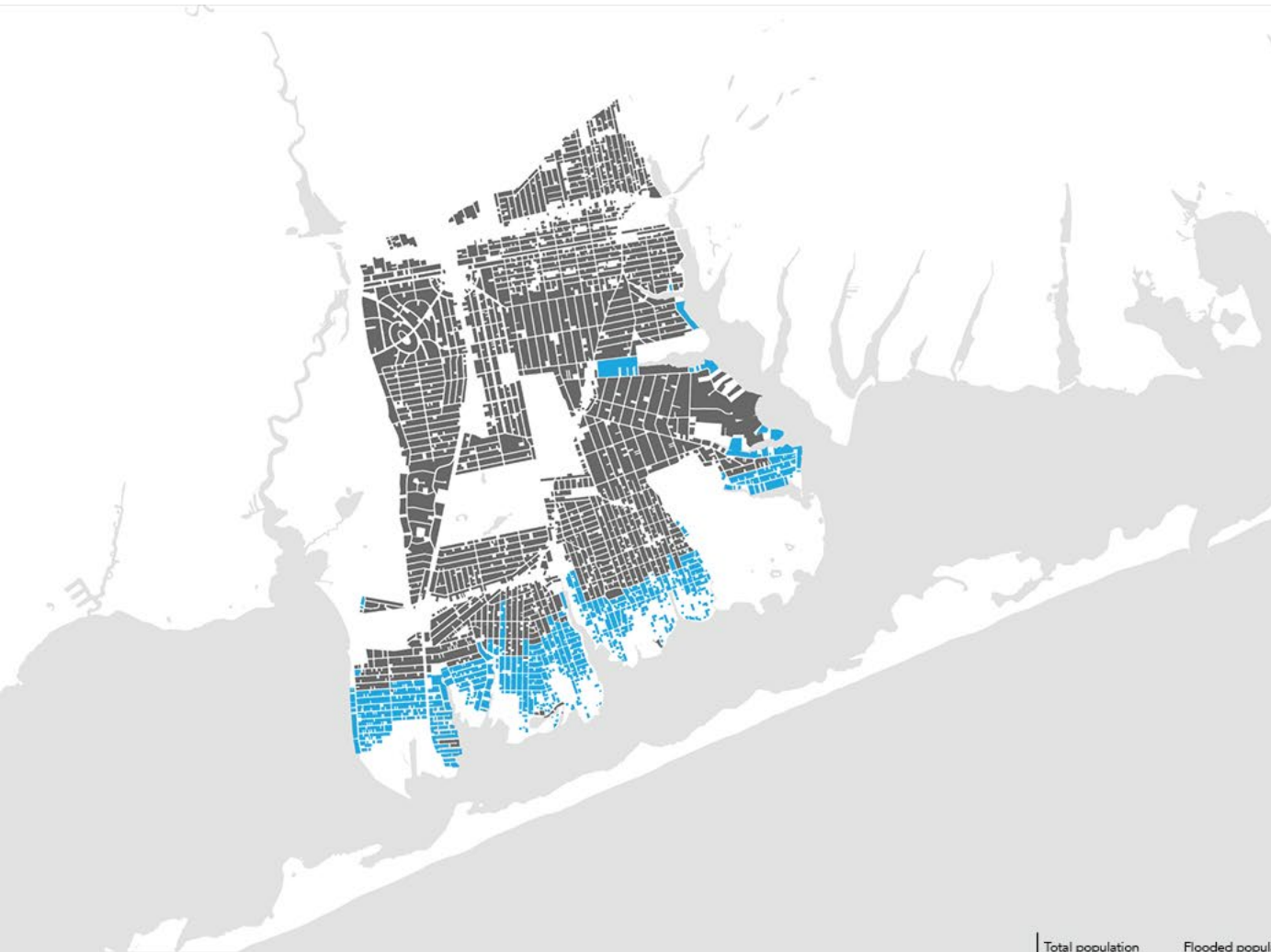

Residential parcels  
 Residential parcels to be flooded by the RPA 2050 Flood Zone



	Total population 2017	Flooded population by 2050	Total population 2067	Natural population growth	Housing need
# people	45,507	6,986	53,926	8,419	13,309
# units	15,695	2,733	16,905	1,210	3,122
Area(sqft)	18,202,800	3,143,700	24,266,608	6,063,808	8,264,398

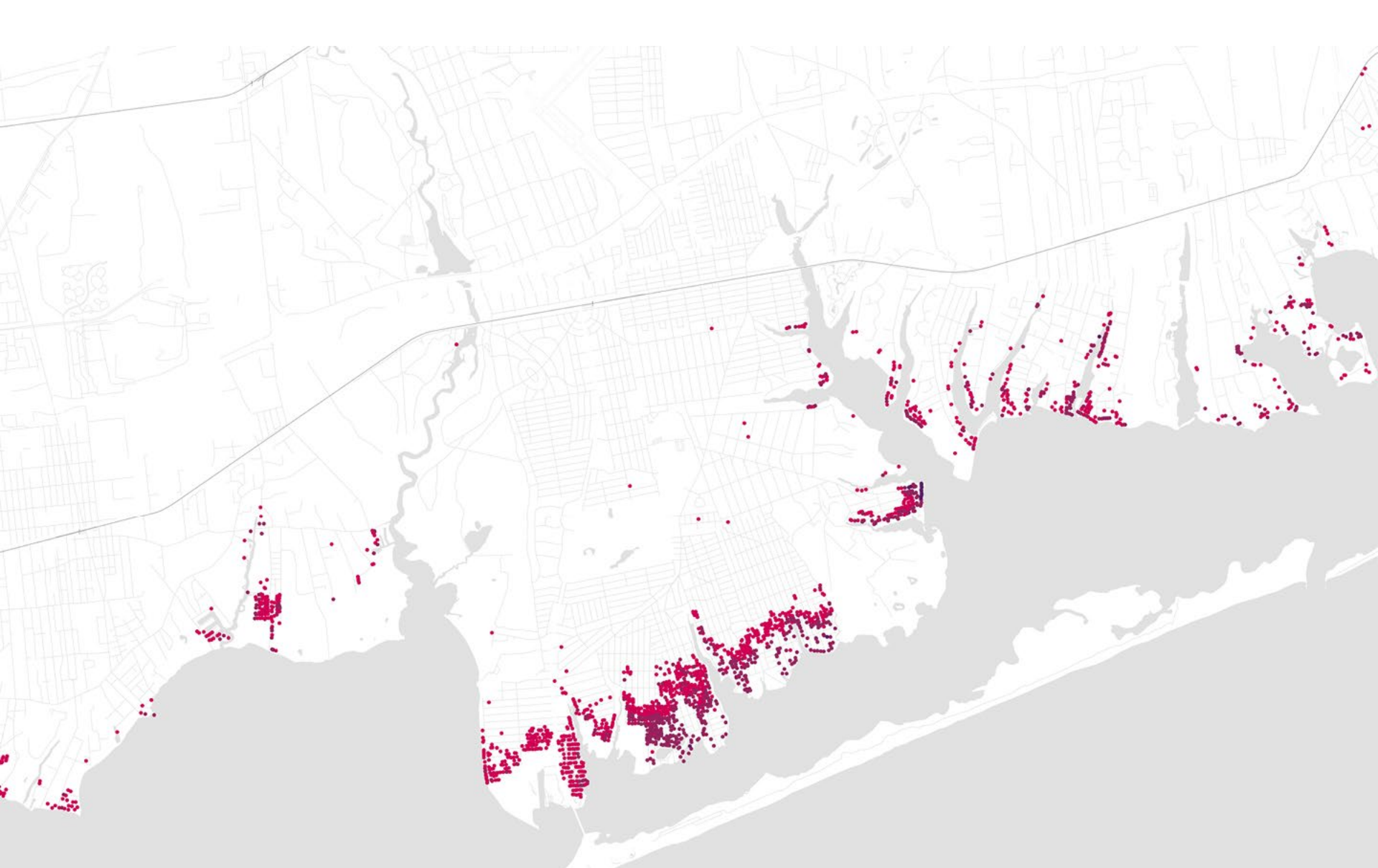

**PROPERTY DAMAGED BY FLOODING DUE TO 2012 HURRICANE SANDY.  
PROPERTY LOSS IN NEW JERSEY WAS ESTIMATED TO BE \$ 8,240,232,000  
AND \$11,919,891,000 IN NEW YORK.**



# HOME BUYOUT PROGRAMS

## IMPACTS AND OPPORTUNITIES

Climate change is increasing flood risk along the coastal floodplain by both raising mean sea level, and creating a higher frequency of intense storms. This increasing flood risk has provoked many to consider “retreat”, a solution that involves removing homes and structures from coastal floodplains. Already, Hurricanes Irene and Sandy have prompted retreat from many coastal areas in metropolitan New York. Retreat is currently carried out through the use of home “buyout” programs. Under home buyout programs, the state or local government purchases houses from residents who are willing to sell them. After sale, the home is demolished, and the property is put under a conservation easement that prevents any future construction in perpetuity. This ensures that buildings and residents are kept out of harm’s way, while allowing the site to perform as a natural floodplain.

Because home buyout programs are voluntary, there is an uneven geography of retreat along the coast of metropolitan New York. In some neighborhoods where buyouts are offered, most homeowners take the buyout offer, leaving only a few homes isolated inside conservation land. Alternatively, sometimes only a handful of residents accept the buyout offer, resulting in a patchwork of vacant lots within an otherwise dense urban or suburban neighborhood. However, when flooding becomes too frequent and costly, its likely entire neighborhoods will voluntarily leave.

It’s important to understand that retreat doesn’t happen all at once. Instead, it takes place over extended time periods, slowly tracking the progress of sea level rise. With each new storm, the perception of risk increases, and homeowners become more willing to relocate. This process will likely take decades. Generations will grow up in these vulnerable, partially empty neighborhoods before they are abandoned for good. Residents that stay must deal with the perception that they live in a dying neighborhood while towns must devote resources to maintaining empty lots.

However, there is much opportunity to be had in these new landscapes. These neighborhoods represent a new type of mixed use community. Residential uses and conservation uses are intertwined in a unique way that doesn’t happen through typical development processes. Rather than seeing vacant lots as a downside, they should be utilized as an asset. Pocket parks, community gardens, or “urban wilds” could offer new amenities to local residents. Communities can also be engaged as stewards of the land and facilitators of the transition from urban uses to conservation uses. Design is critical for resolving this clash of uses and of users. Only design can provide novel ways of ensuring privacy, security, and productivity while maximizing the performance of the natural floodplain.



# SENDING AND RECEIVING BLOCKS

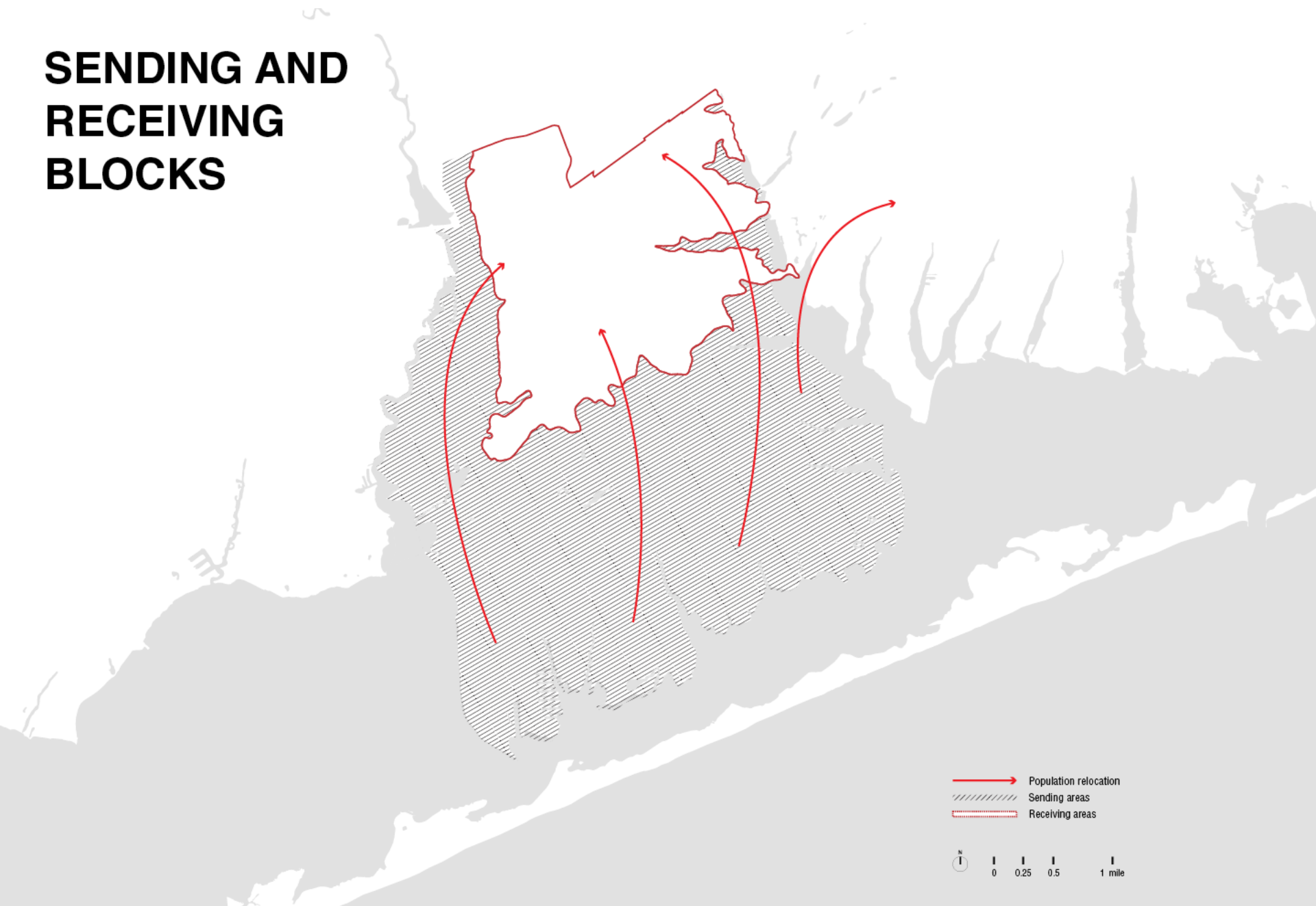



Sending Area: Existing

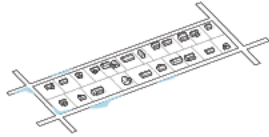

Sending Area: Island



Sending Area: Curved

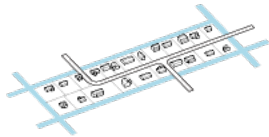

Sending Area: Scattered

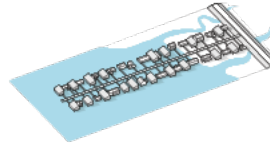

Sending Area: After First Round of Dispute

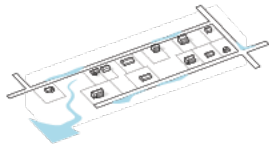

Sending Area: Boardwalk

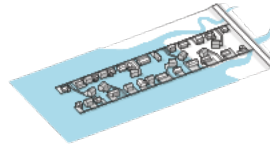

Sending Area: After Second Round of Dispute

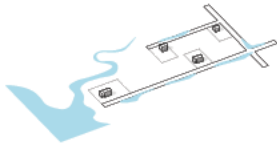

Sending Area: Elevated Plaza

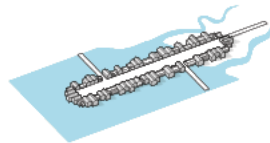

Receiving Area: Existing

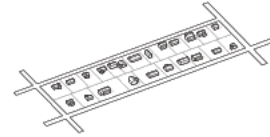

Receiving Area: Withable Blocks

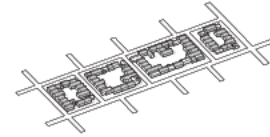

Receiving Area: Commercial Block

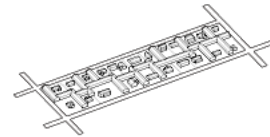

Receiving Area: Split Block

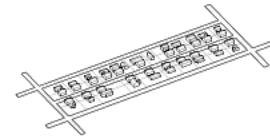

Receiving Area: Typical Subdivision

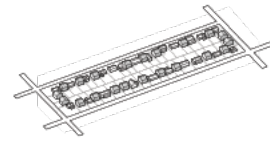

Receiving Area: Penitentiary

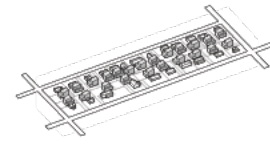

Receiving Area: Townhouse Subdivision

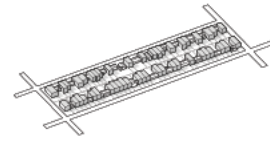

Receiving Area: Split Block with Duplexes

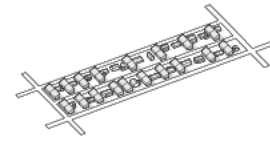

SENDING



RECEIVING

# 2017

45 THOUSAND PEOPLE  
RESIDENTIAL AREA: 0.65 SQUARE MILES

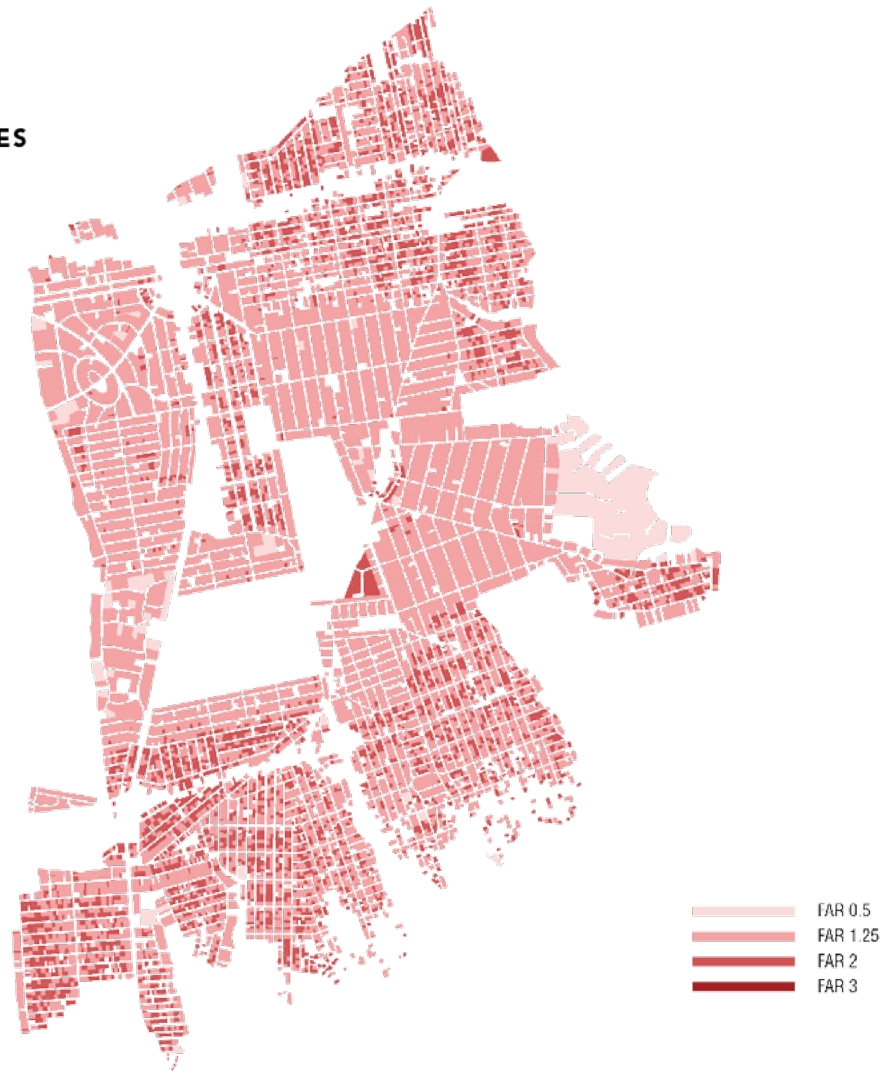



# 2067

54 THOUSAND PEOPLE  
RESIDENTIAL AREA: 0.87 SQUARE MILES

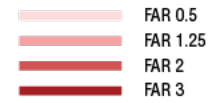
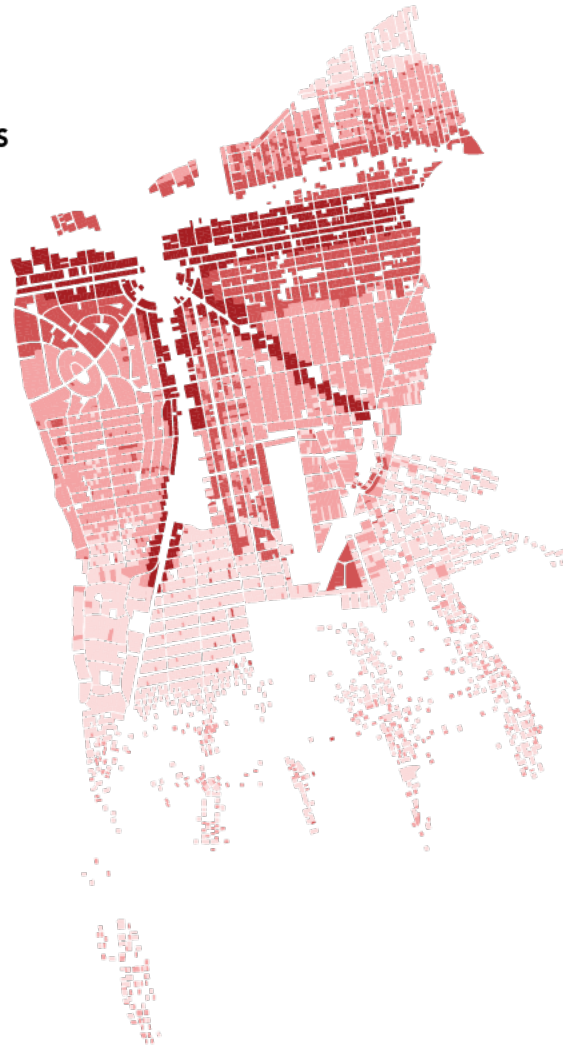



**PROJECTED FLOODING ZONE IN 2050**

— RPA 2050 Flood Zone





**MASTIC BEACH 2047**

For the use of Long Beach High School, 1000 Long Beach Expressway, Mastic Beach, NY 11950. This map is a reproduction of the original map and is not to be used for any other purpose. All rights reserved. © 2017. All other rights reserved. For more information, please contact the author.



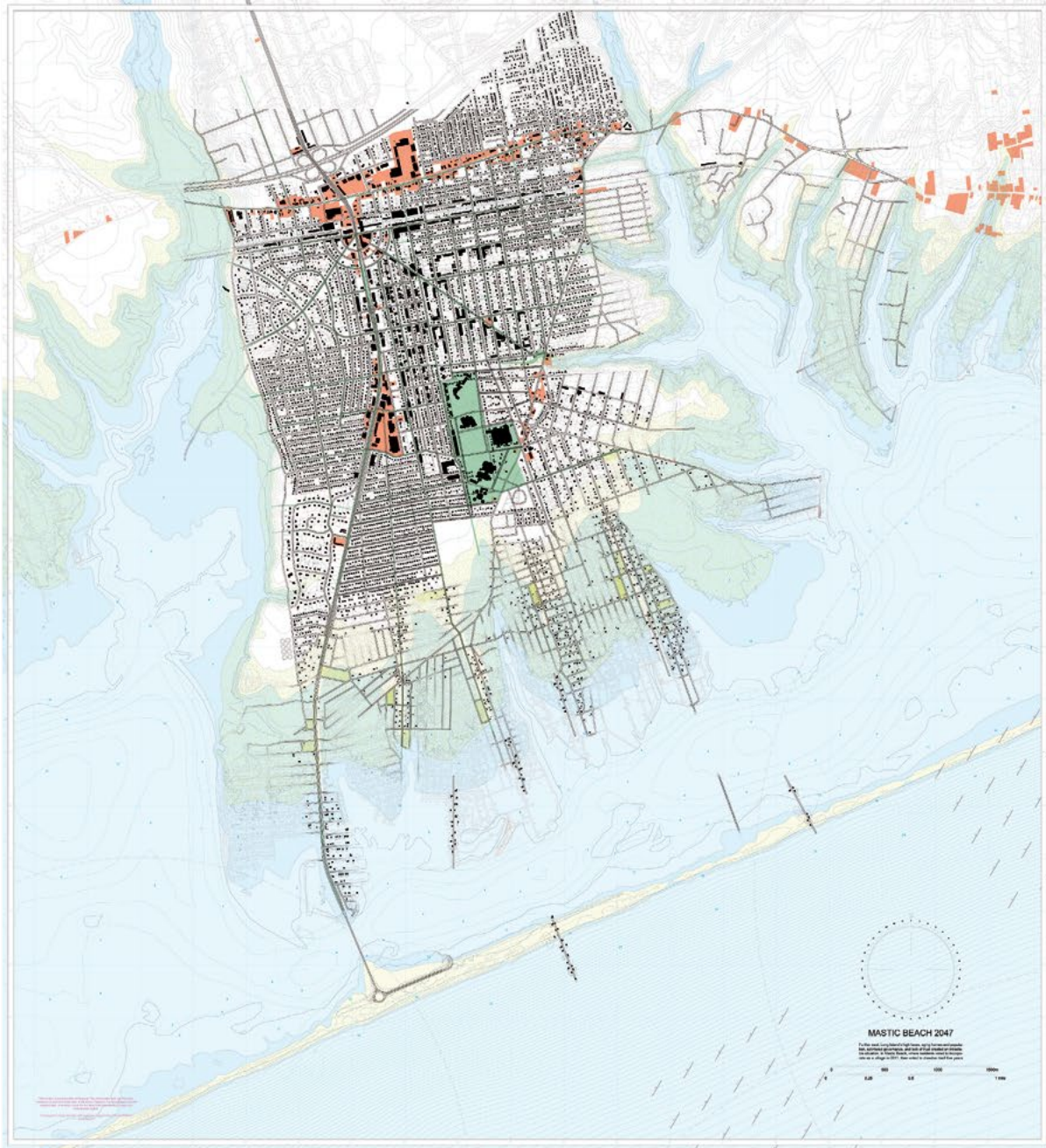



# THREE-ZONE URBANISM

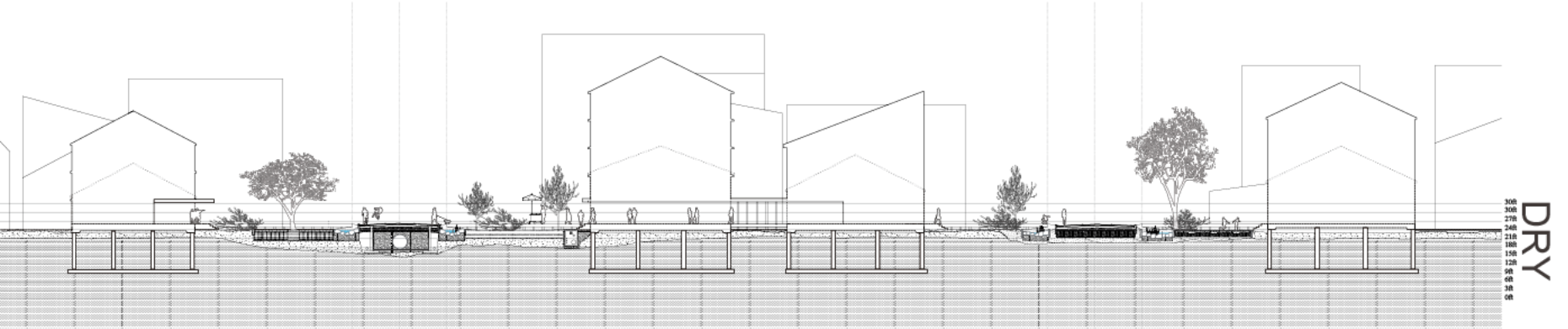

DRY

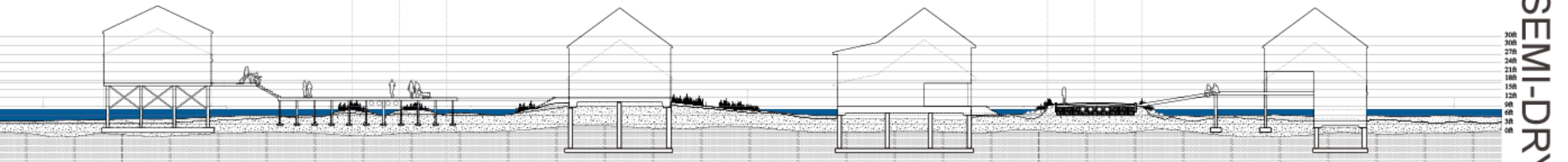

SEMI-DRY

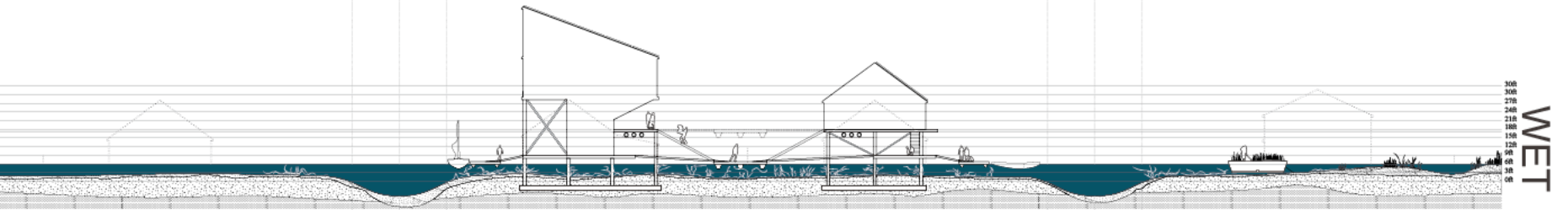

WET











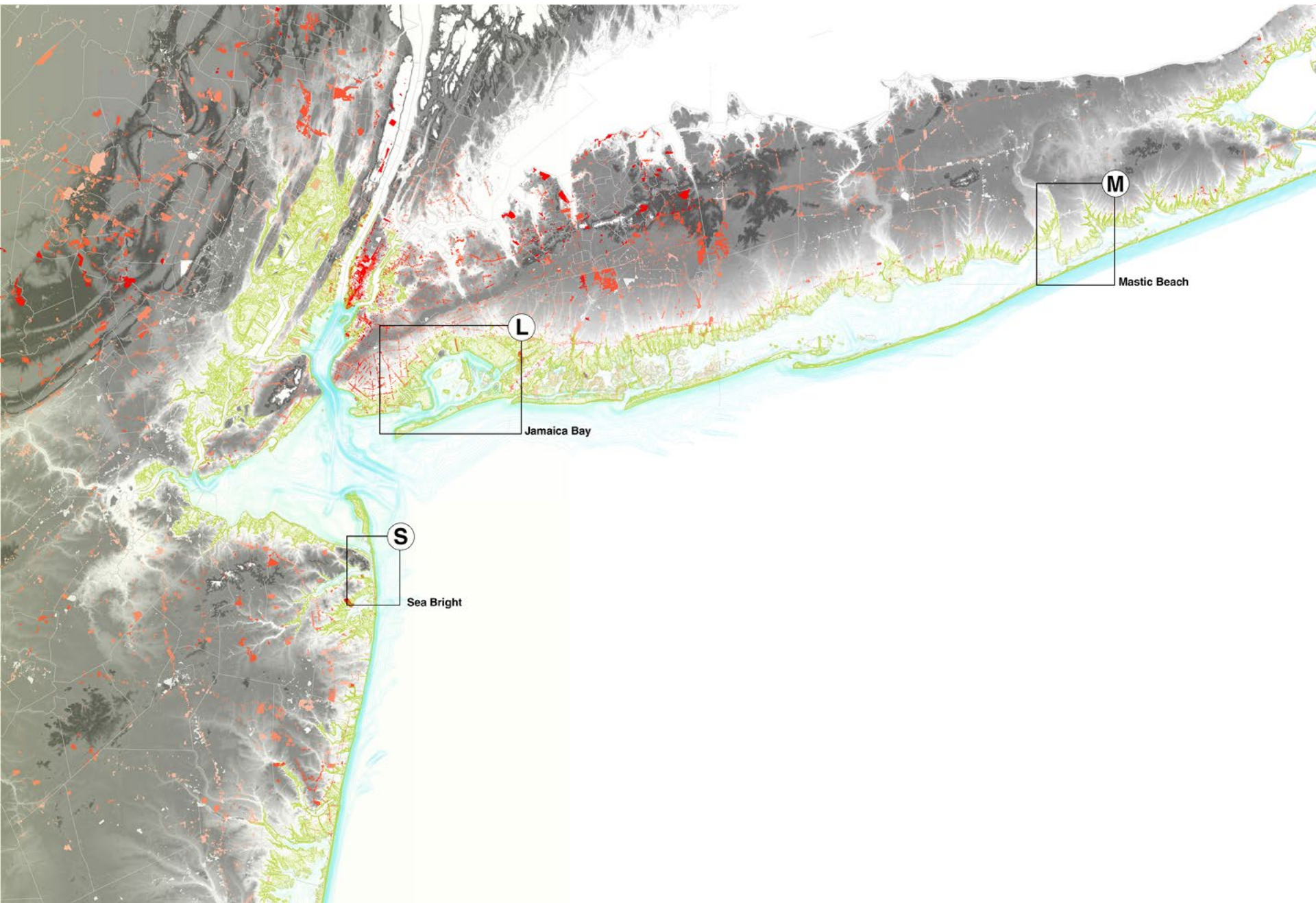

L

Jamaica Bay

M

Mastic Beach

S

Sea Bright





# JAMAICA BAY

L



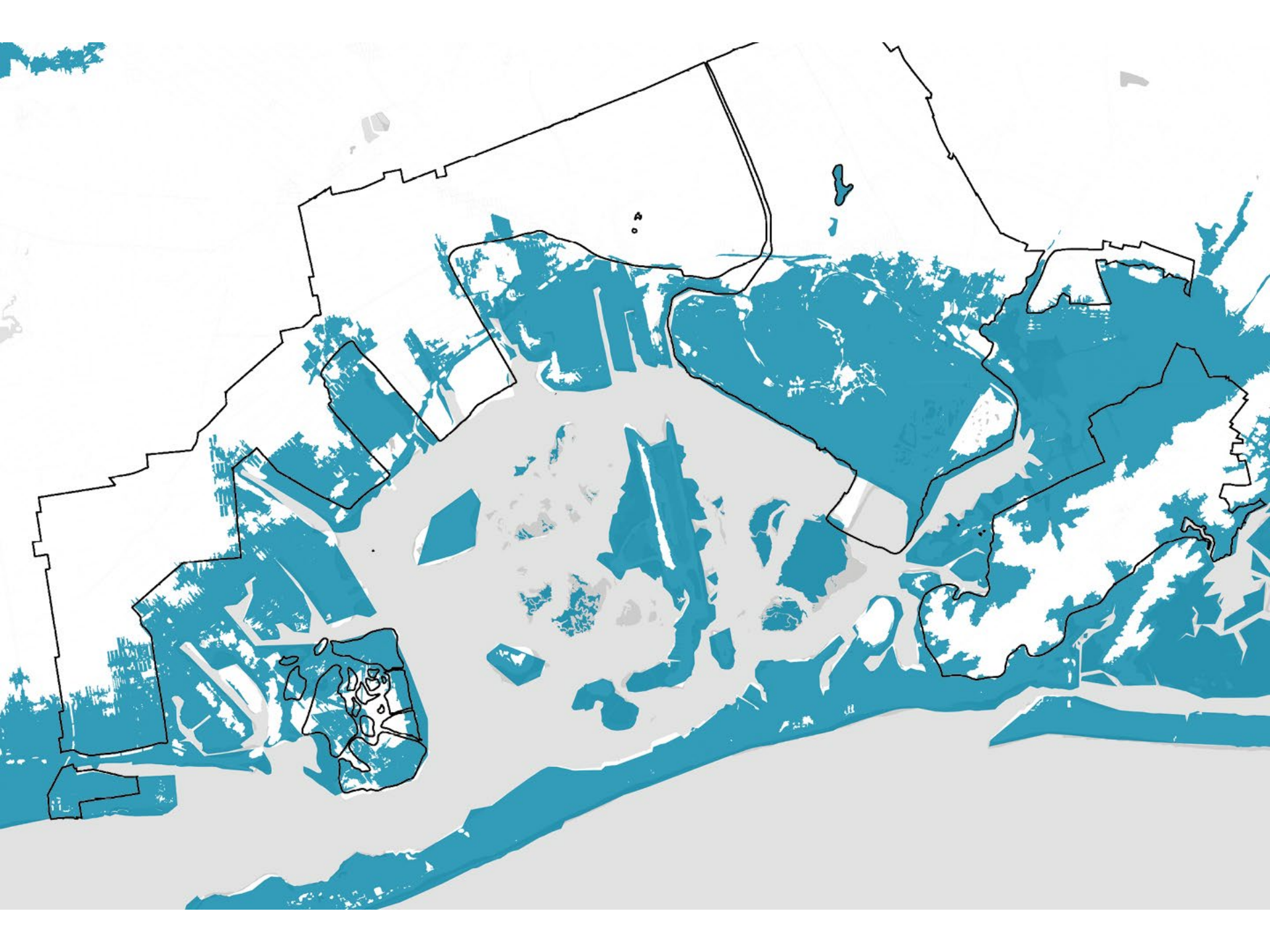



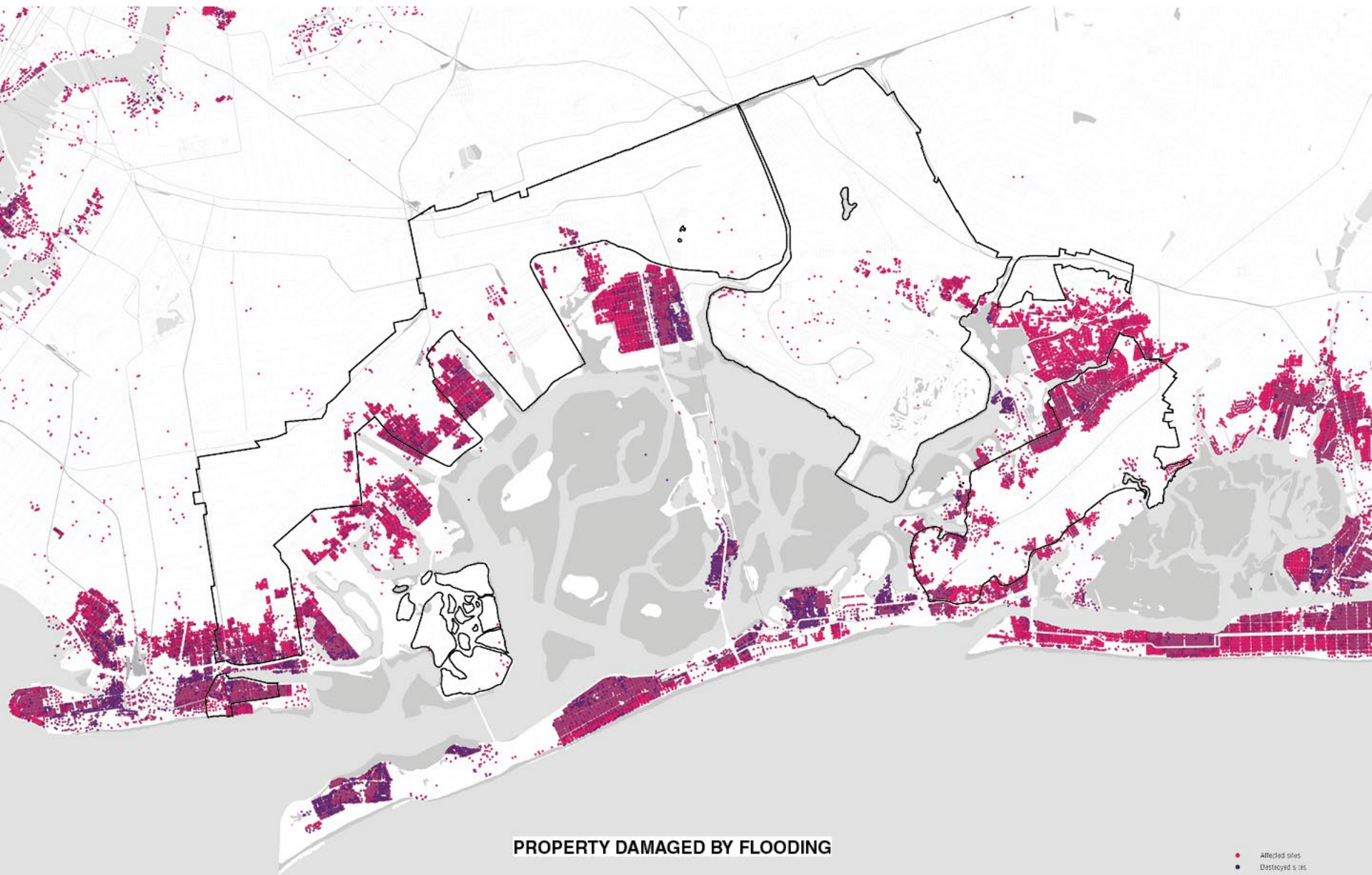

**PROPERTY DAMAGED BY FLOODING**

- Affected sites
- Destroyed sites
- Major sites
- Minor sites





DAMAGE FROM FLOODING







# JAMAICA BAY 2067

INTERVIEW WITH CHAEWON AHN,  
BIGHT CITY RESIDENT



OFF-CAMERA INTERVIEWER: ...just hold still; the HoloLens needs to triangulate your location for few a seconds so it can accurately capture your depth... Done. Okay, recording. Would you say your name please?

CHAEWON: Chaewon Ahn.

INTERVIEWER: Great, thanks again for doing us, Chaewon. As Rafi explained, this is for Bight City's 25th anniversary holodoc, which will loop continuously at Ascendas-Singbridge's sales centers across Asia, including their headquarters in Singapore.

CHAEWON: [nods nervously]

INTERVIEWER: Before we get started, I'm going to read you a brief voiceover, just so you understand the context in which your memories are being presented. Ready?



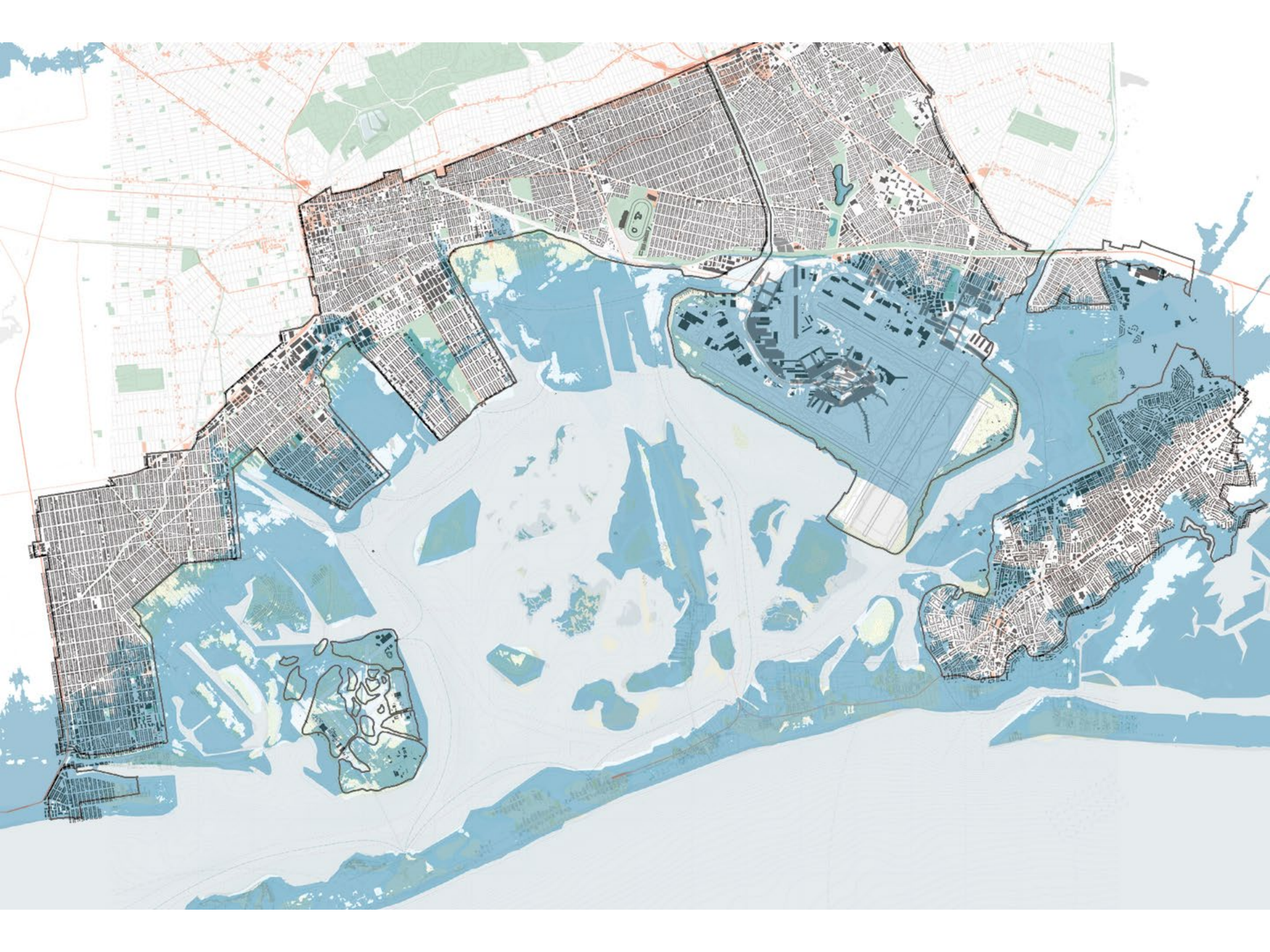



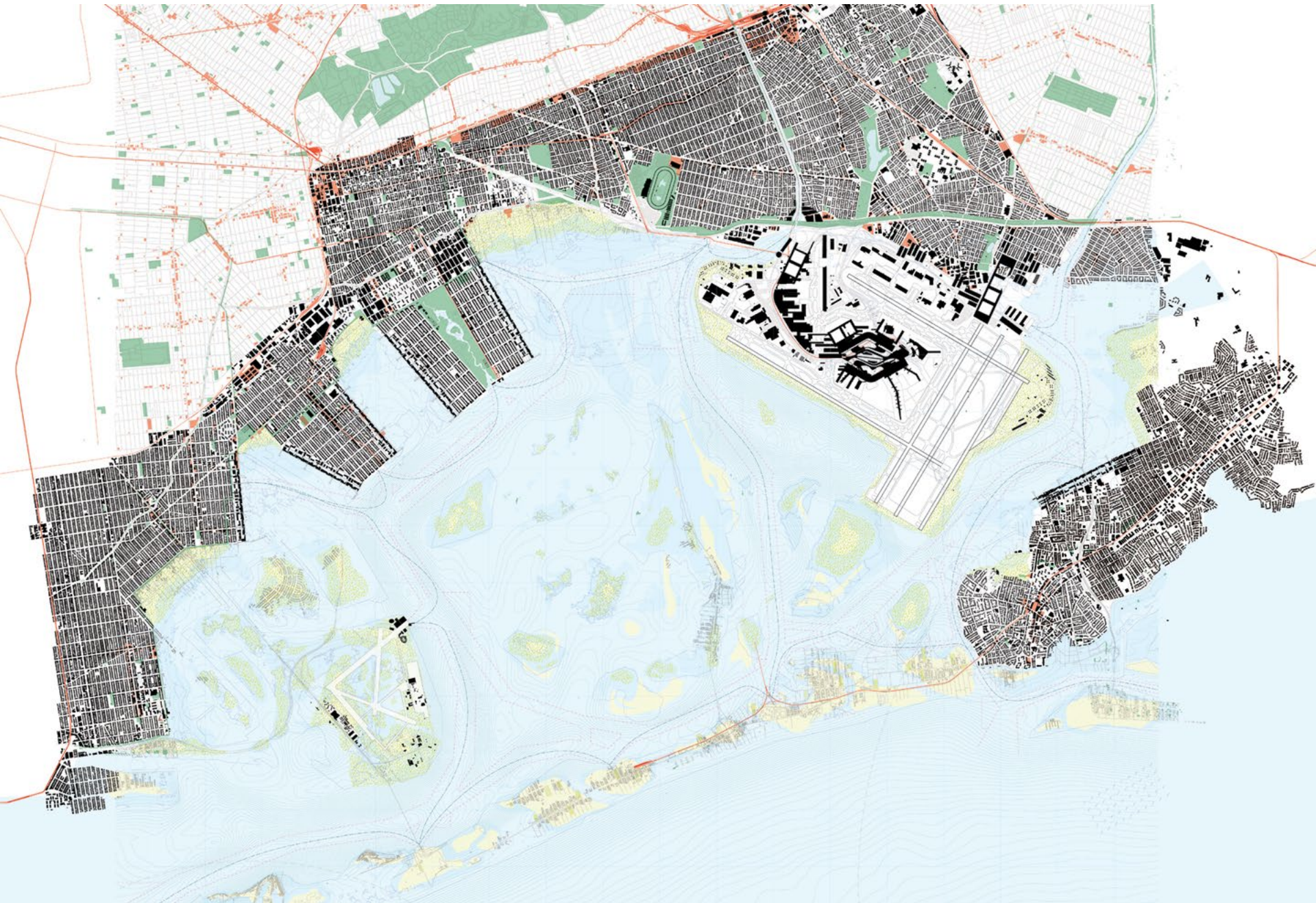



# JFK

2017:

**4 RUNWAYS**  
**60 MILLION PASSENGERS**  
**1.4 MILLION TONS CARGO**  
**285,000 JOBS SUPPORTED**  
**\$37 BILLION REGIONAL BENEFITS**

2067:

**6 RUNWAYS**  
**100 MILLION PASSENGERS**  
**500,000 JOBS SUPPORTED**  
**\$55 BILLION REGIONAL BENEFITS**  
**\$120 MILLION ECO-FUND\***

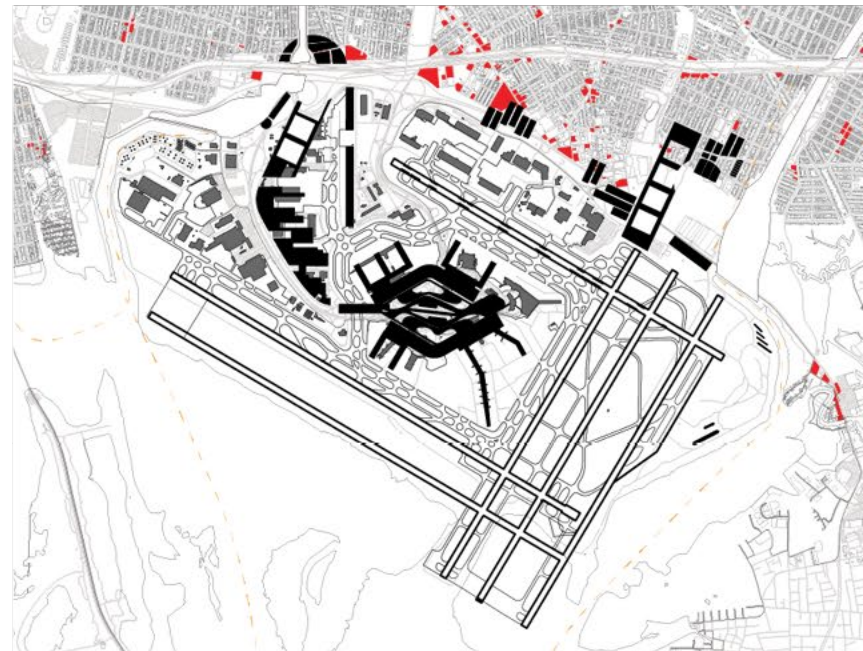

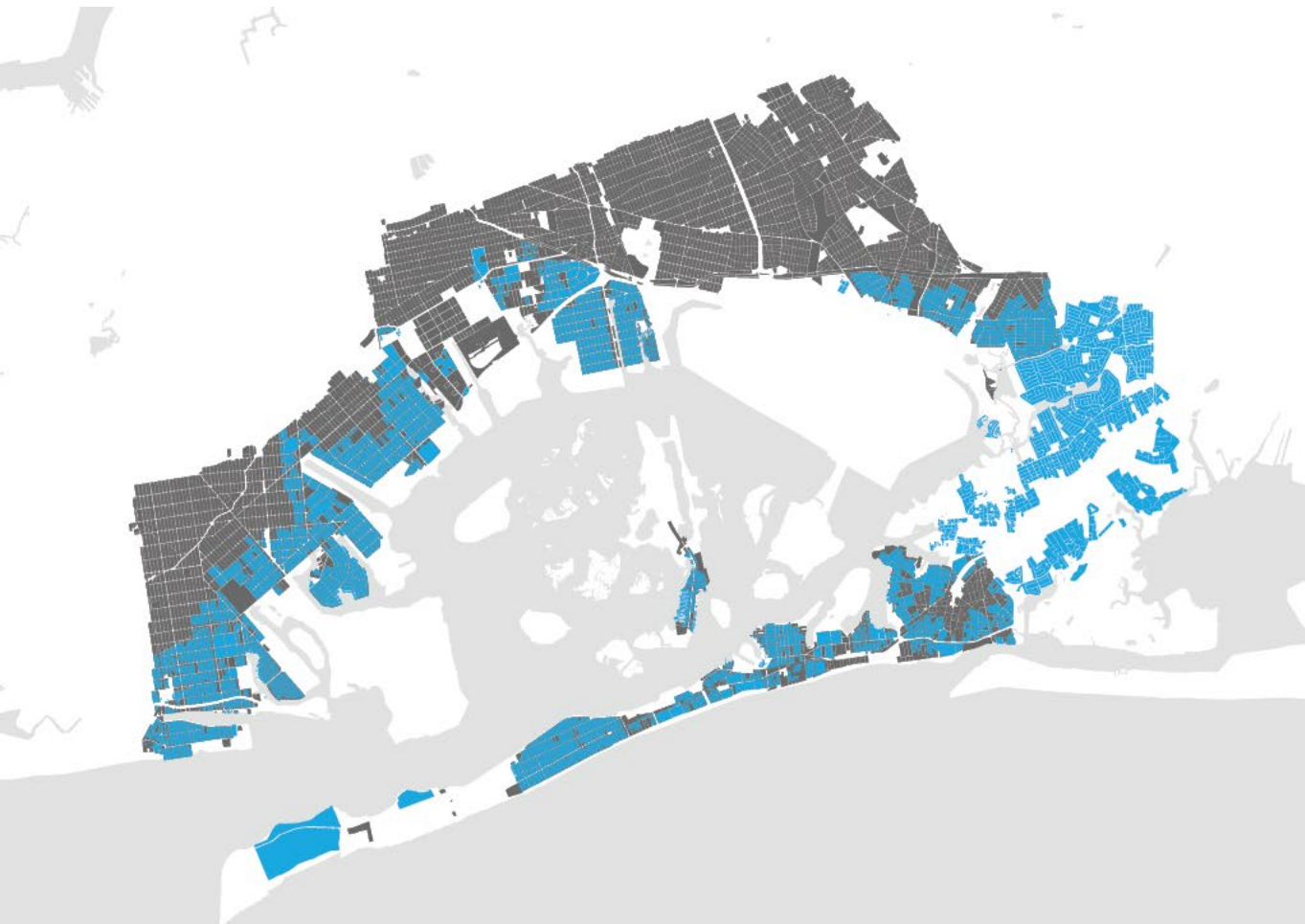

Residential parcels  
 Residential parcels to be flooded by the RPA 2050 Flood Zone



	Total population 2017	Flooded population by 2050 based on current housing condition	Total population 2067	Natural population growth	Housing need
# people	1 million	408K	1.2 million	186K	472K
# units	375K	158K	*444K	69K	180K
Area(sqft)	403,602,000	183,736,350	538,051,916	134,449,916	263,065,361





**SENDING AND RECEIVING  
NEIGHBORHOODS**

- Population relocation
- Sending areas
- Receiving areas



Sending Area: 2017

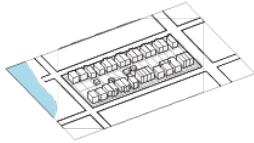

Sending Area: 2017

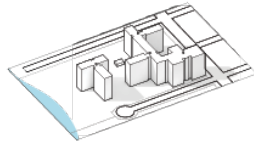

Receiving Area: 2017

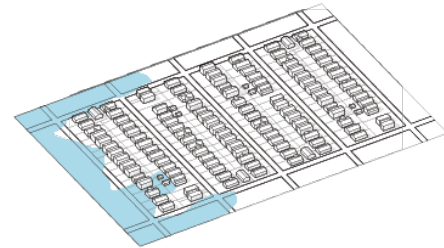

Sending Area: 2027

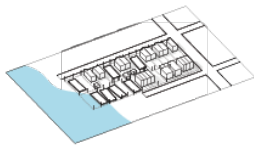

Sending Area: 2027

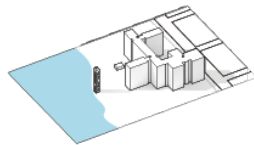

Receiving Area: 2027

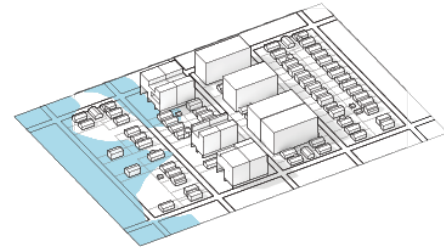

Sending Area: 2067

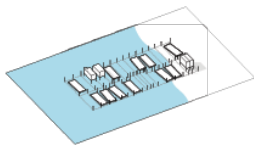

Sending Area: 2067

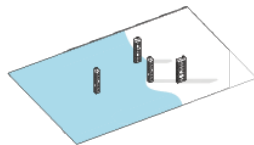

Receiving Area: 2067

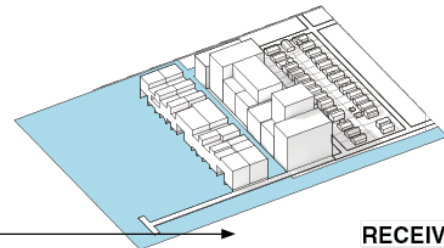

**SENDING**



**RECEIVING**



2017

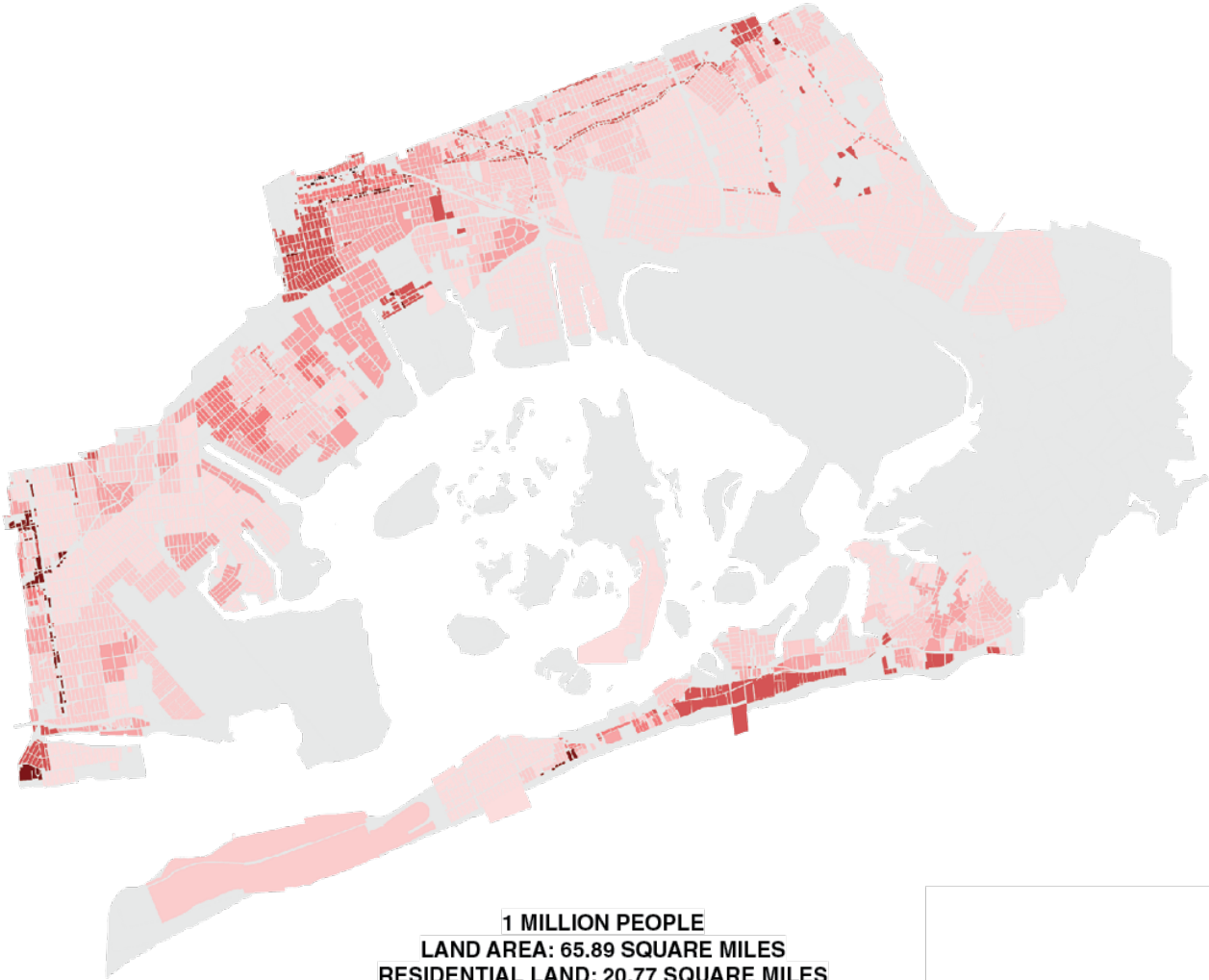

**1 MILLION PEOPLE**  
**LAND AREA: 65.89 SQUARE MILES**  
**RESIDENTIAL LAND: 20.77 SQUARE MILES**  
**AVERAGE FAR: 0.86**

- FAR 0.5
- FAR 0.75
- FAR 0.85
- FAR 0.9
- FAR 1.1
- FAR 1.25
- FAR 1.35
- FAR 2
- FAR 3
- FAR 3.44
- FAR 4
- FAR 6

2067

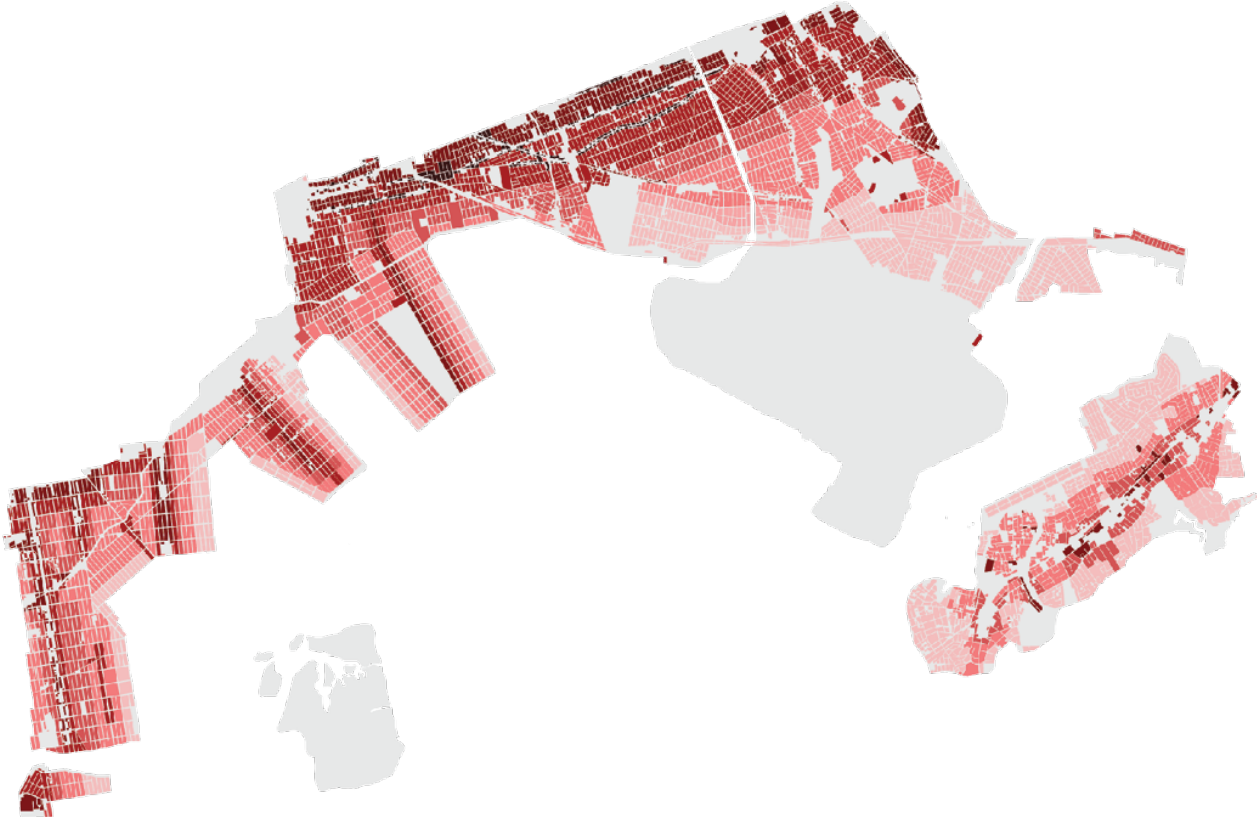

**1.2 MILLION PEOPLE**  
**LAND AREA: 38.64 SQUARE MILES**  
**RESIDENTIAL LAND: 19.97 SQUARE MILES**  
**AVERAGE FAR: 1.66**

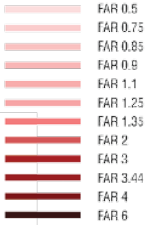



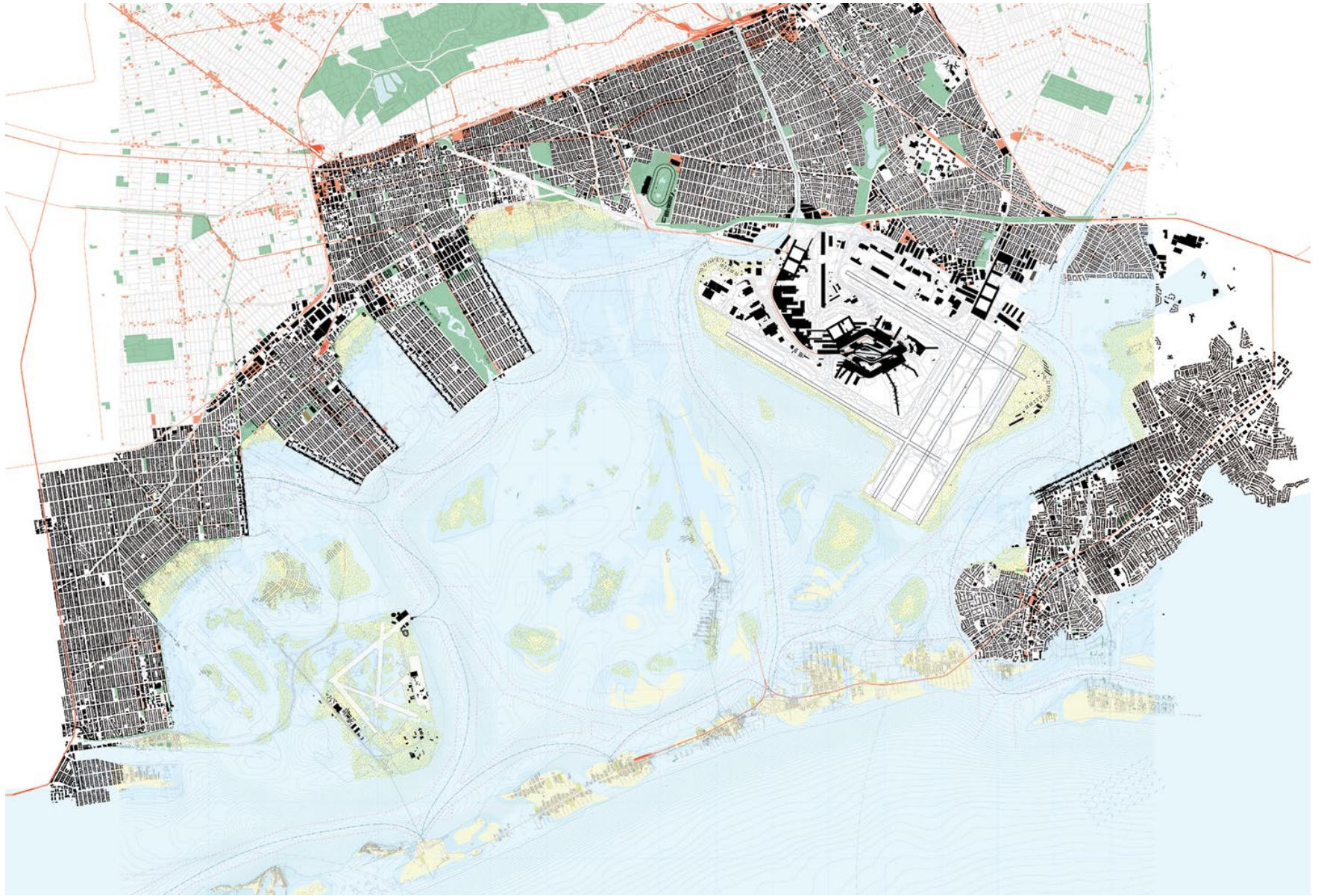



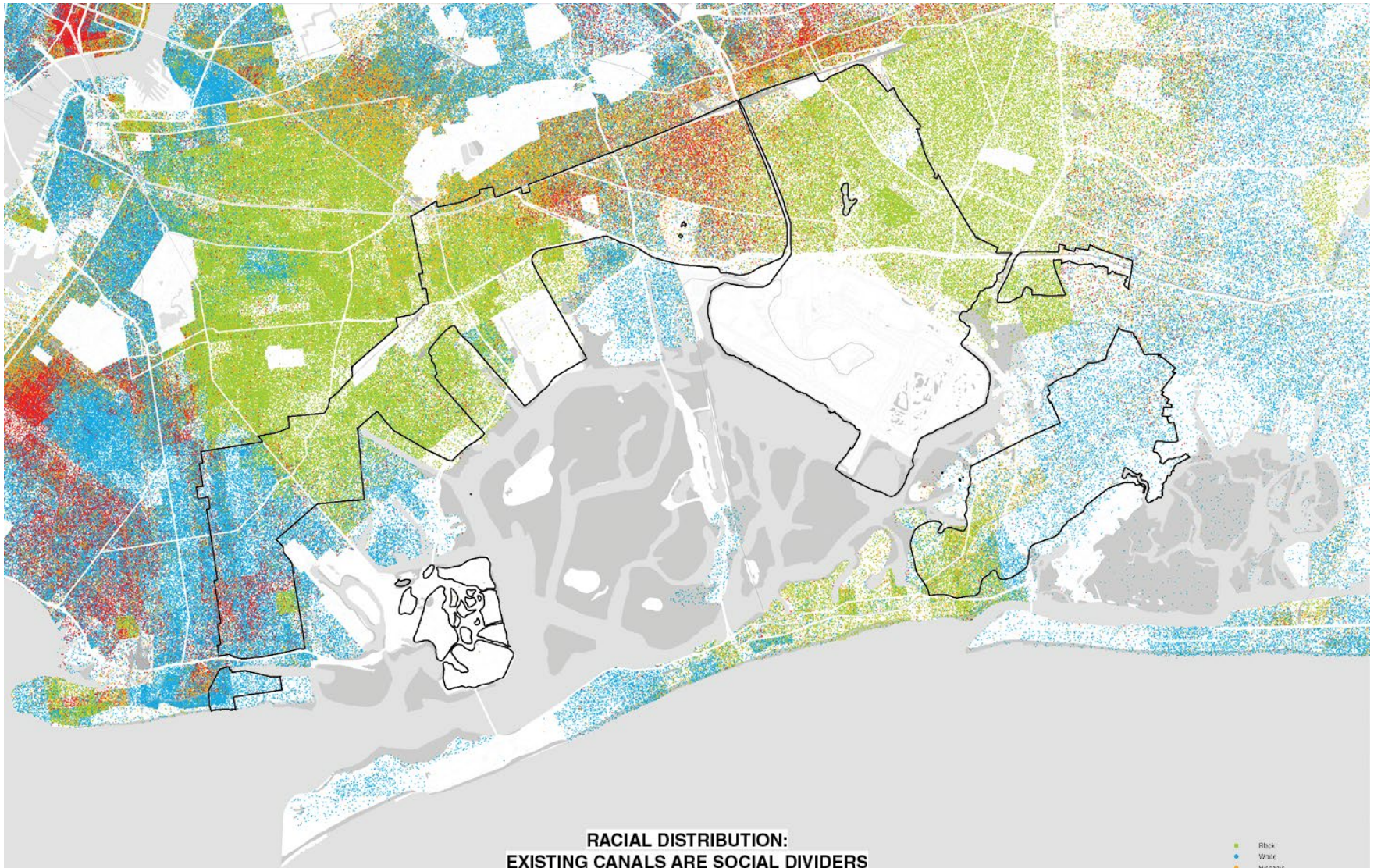



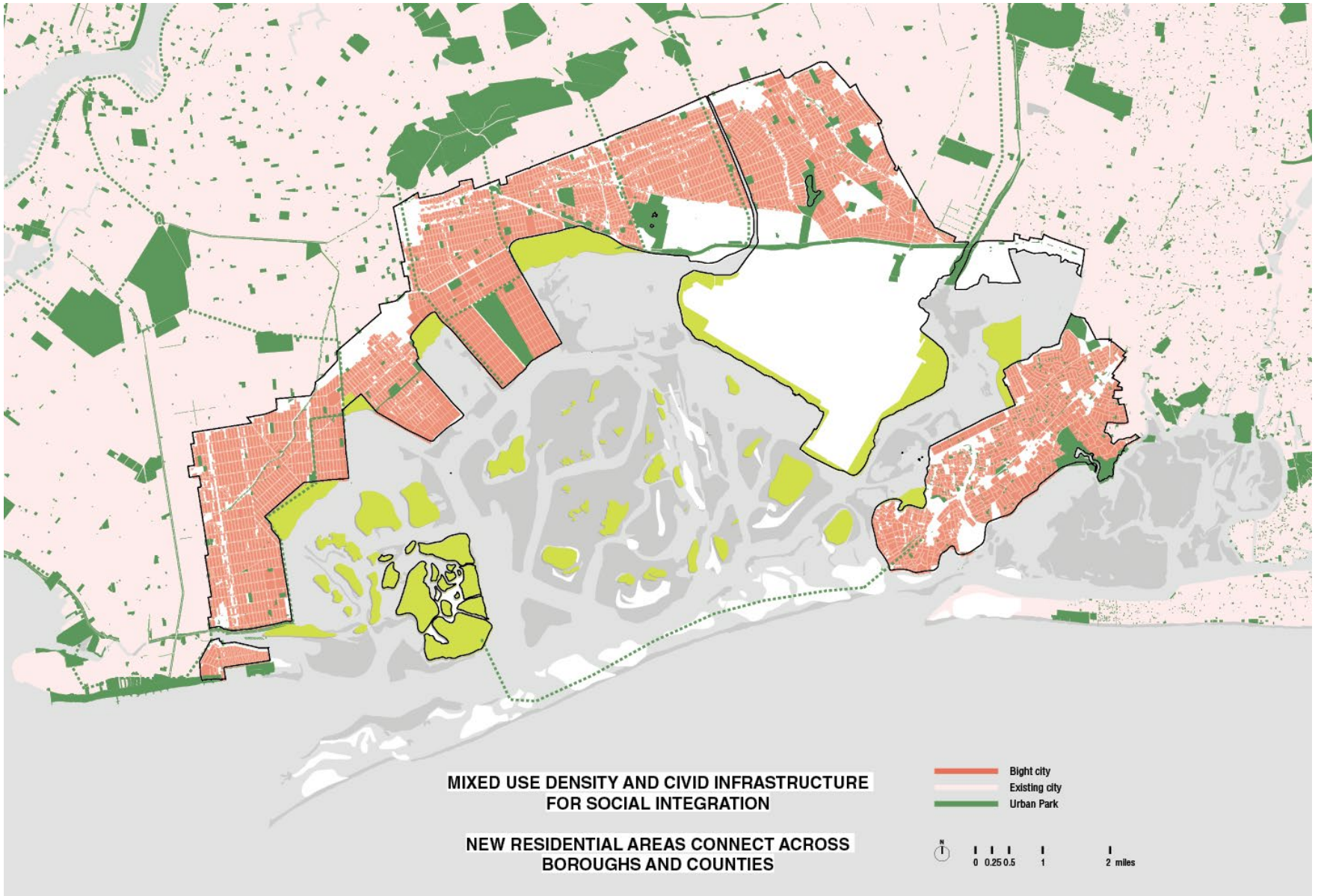



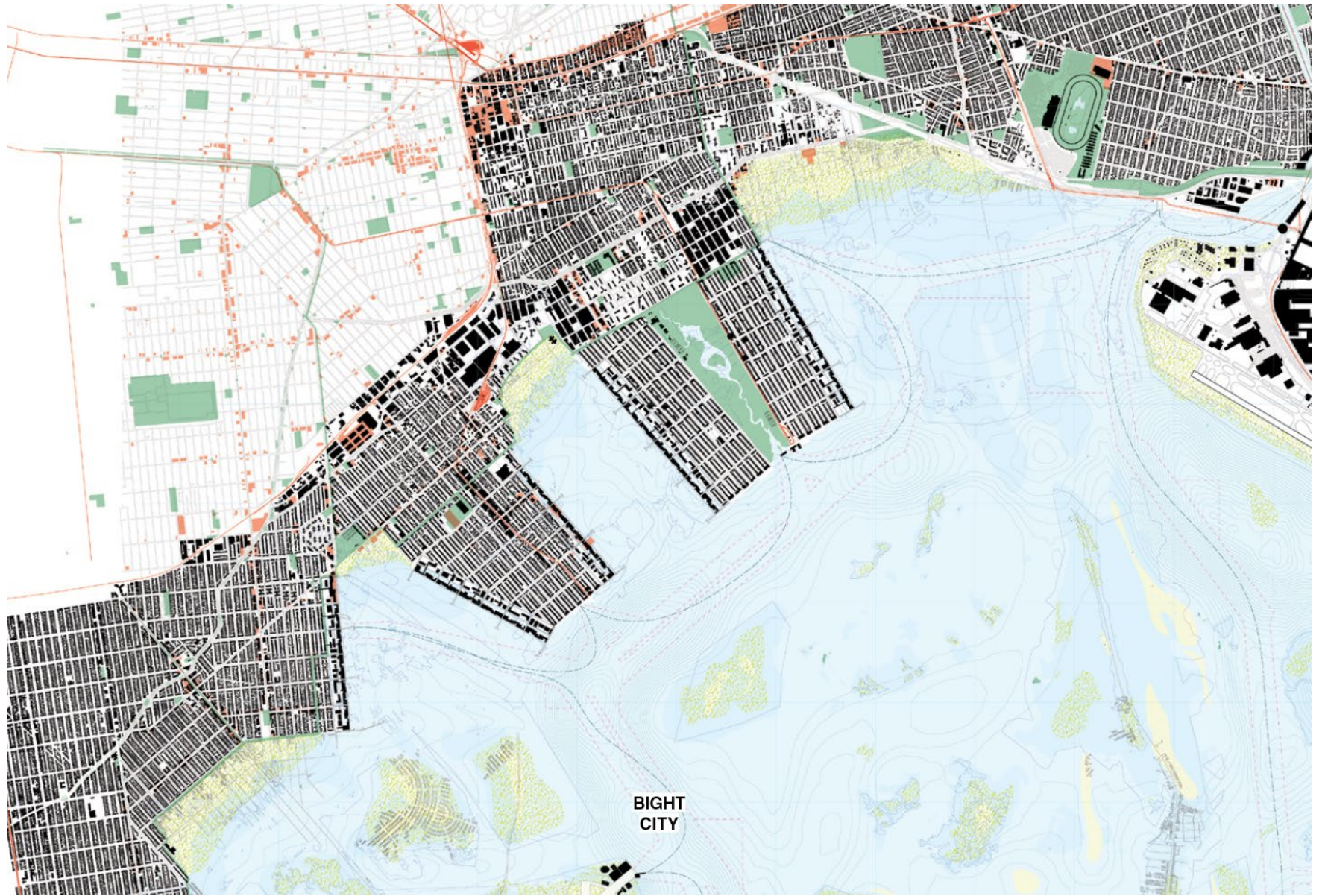

BIGHT  
CITY



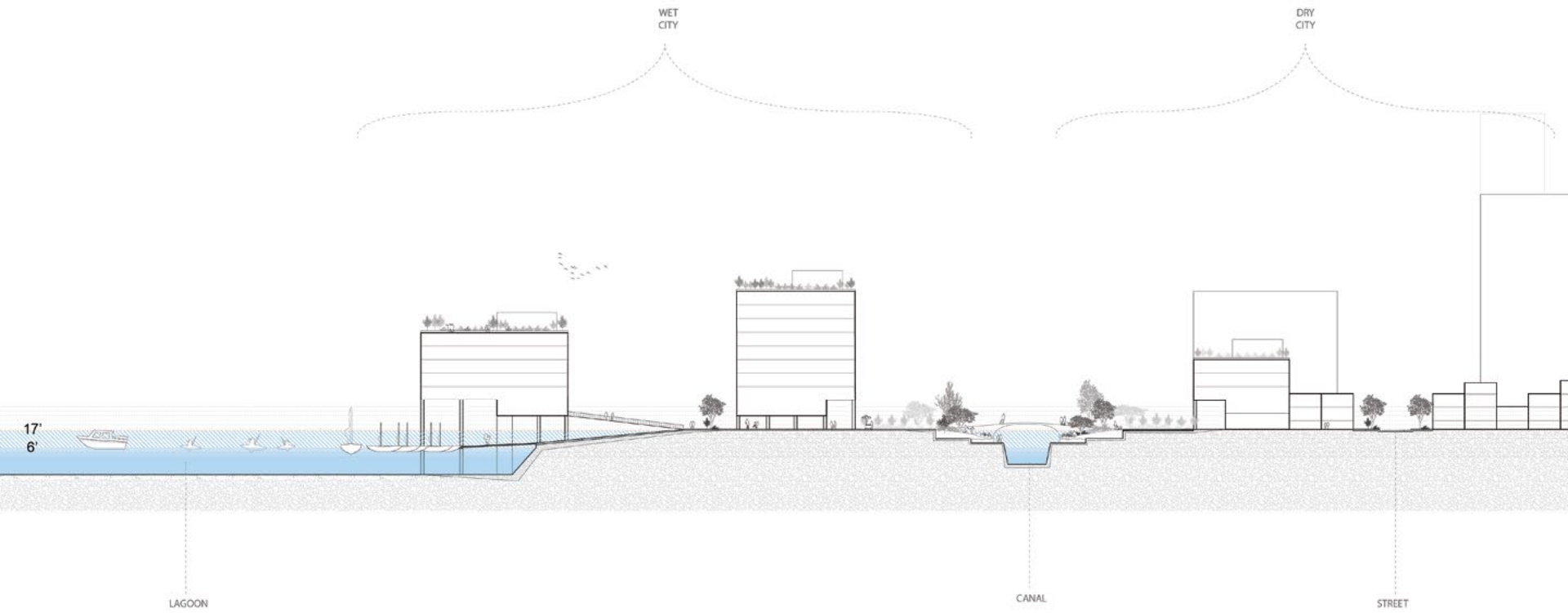

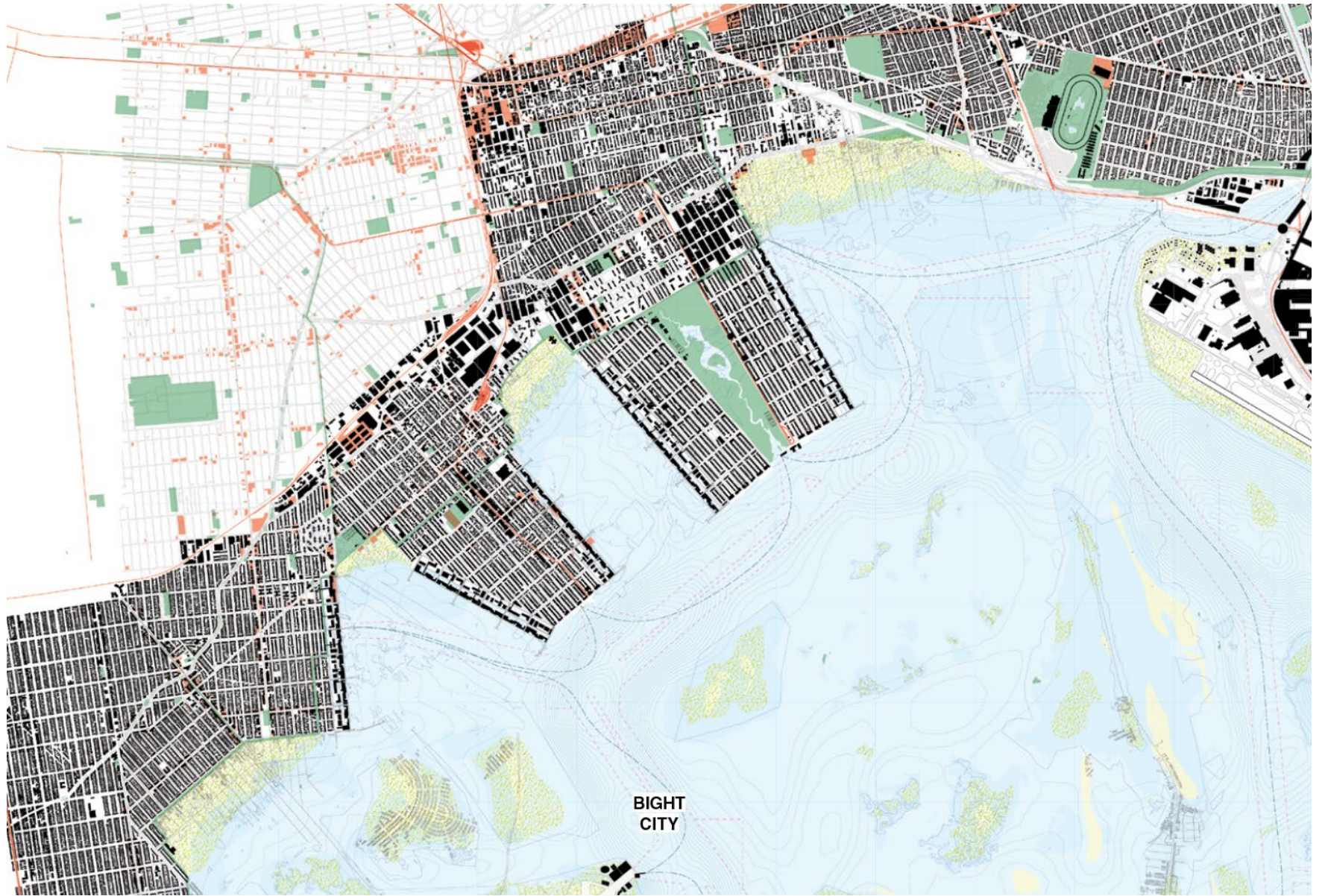



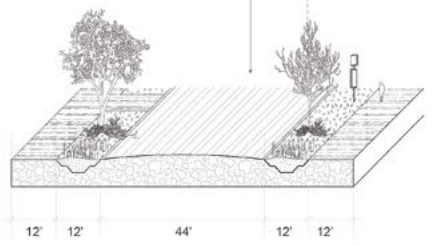





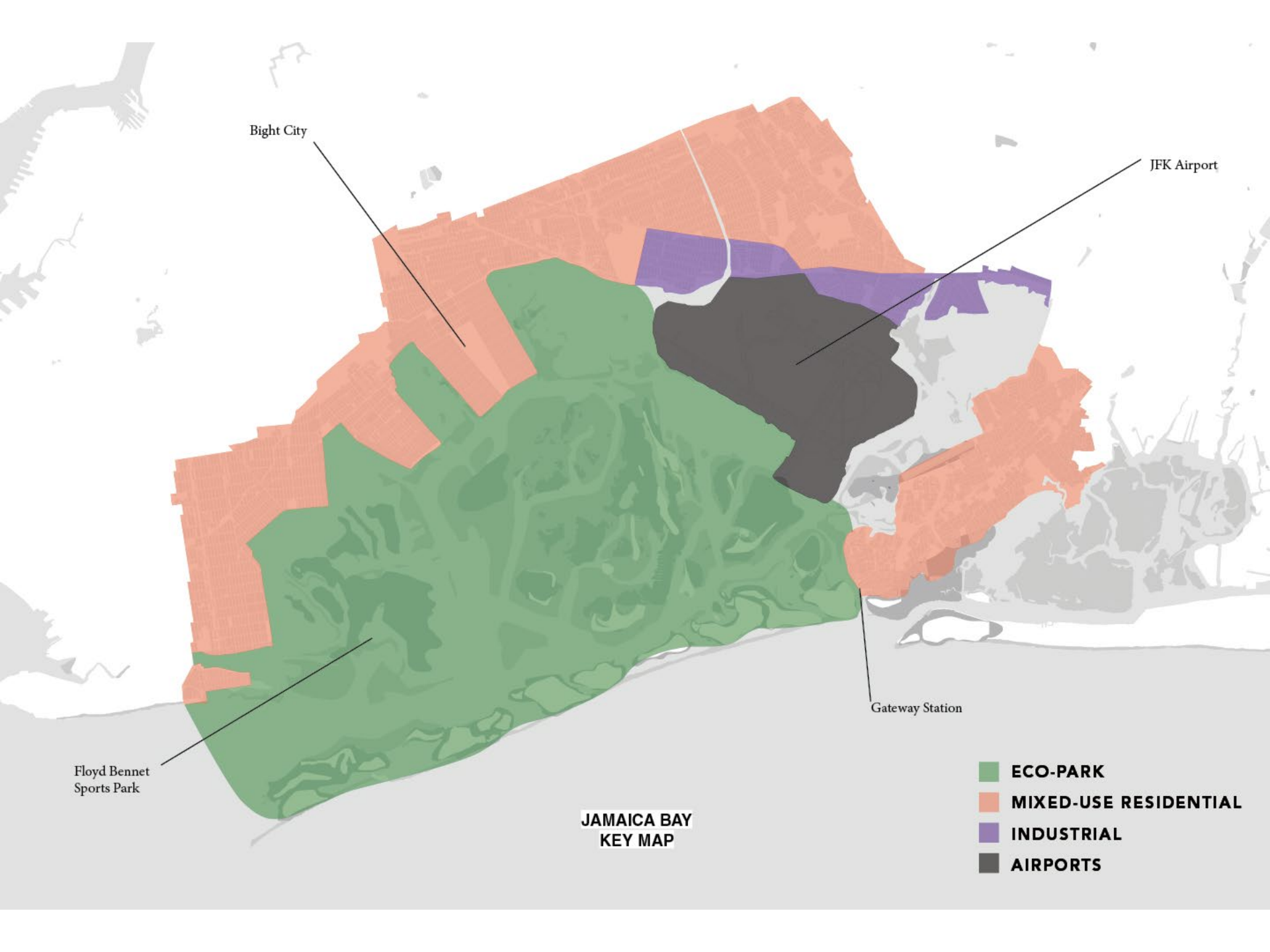

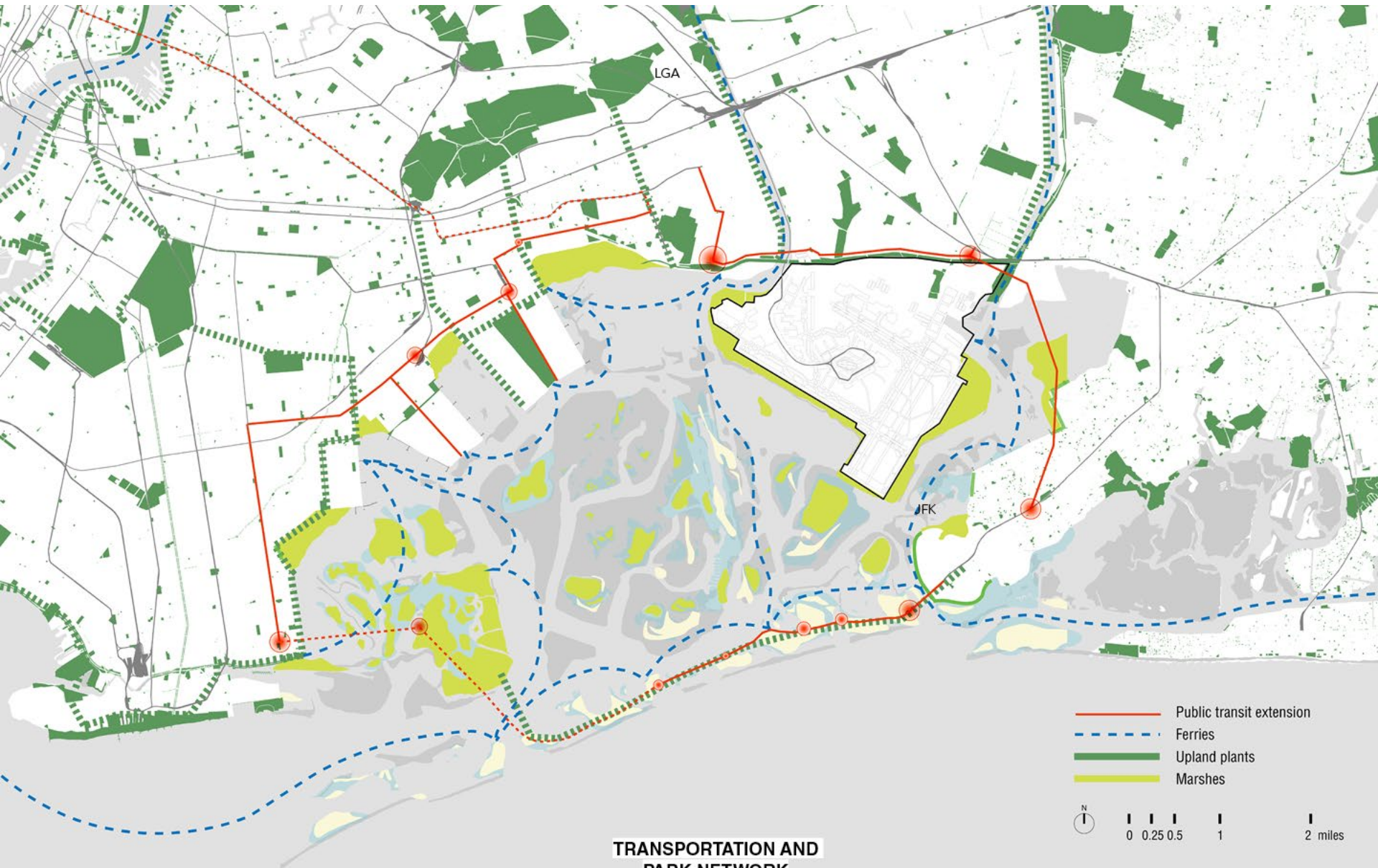

**TRANSPORTATION AND  
PARK NETWORK**

- Public transit extension
- Ferries
- Upland plants
- Marshes







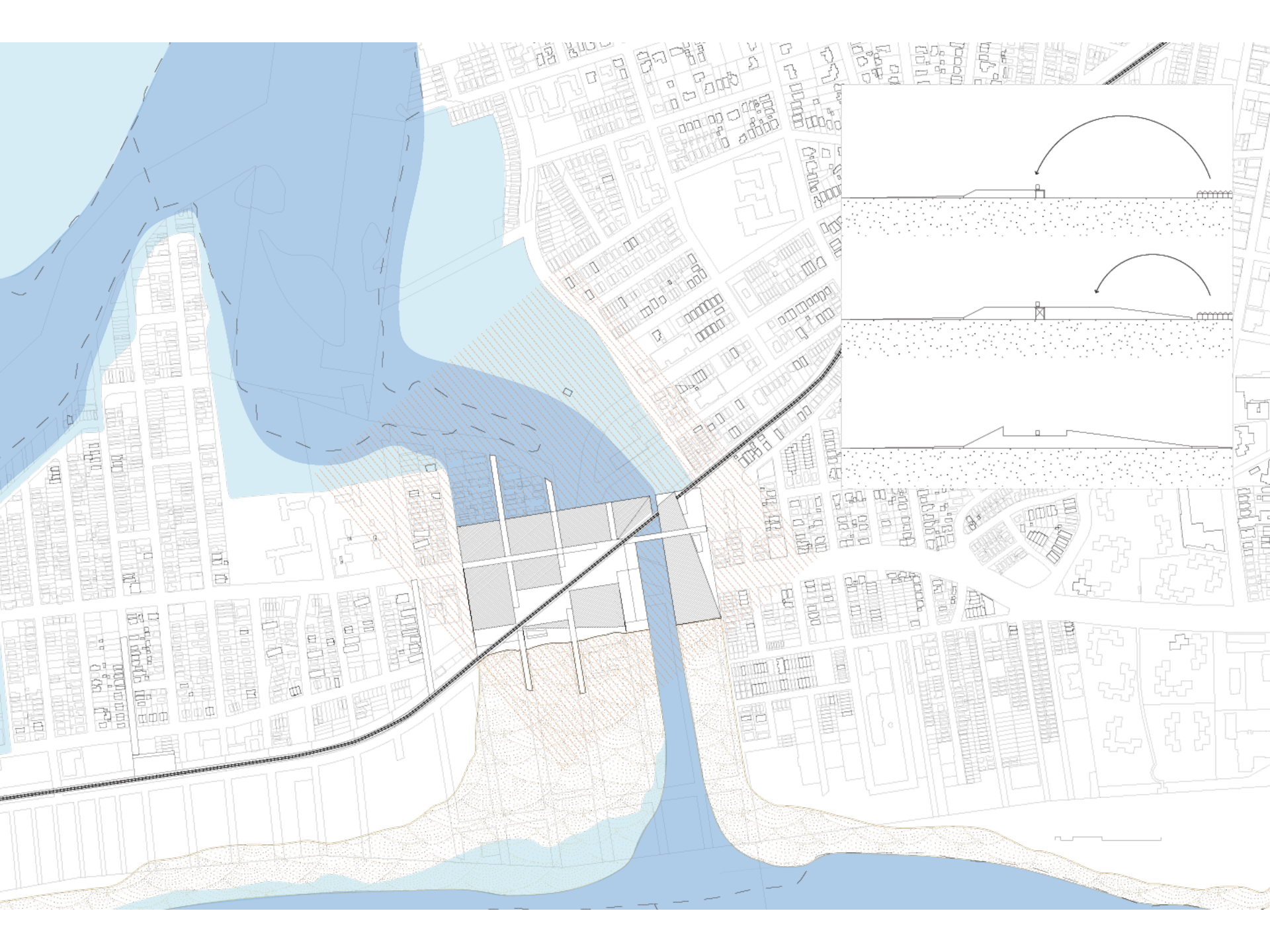



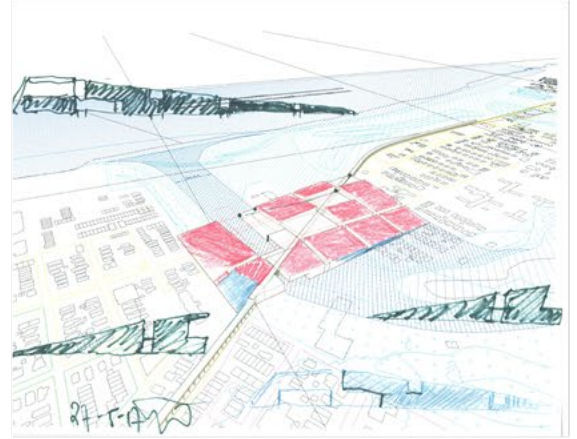
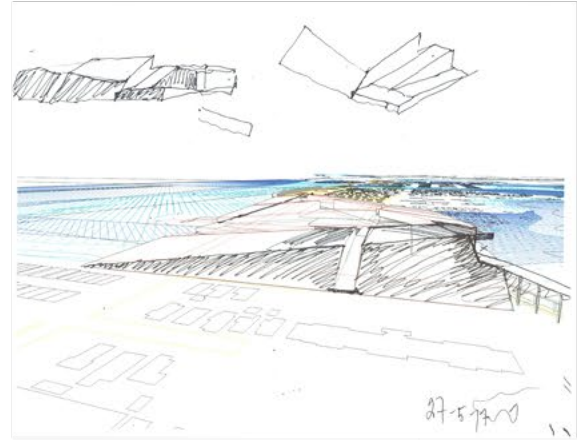
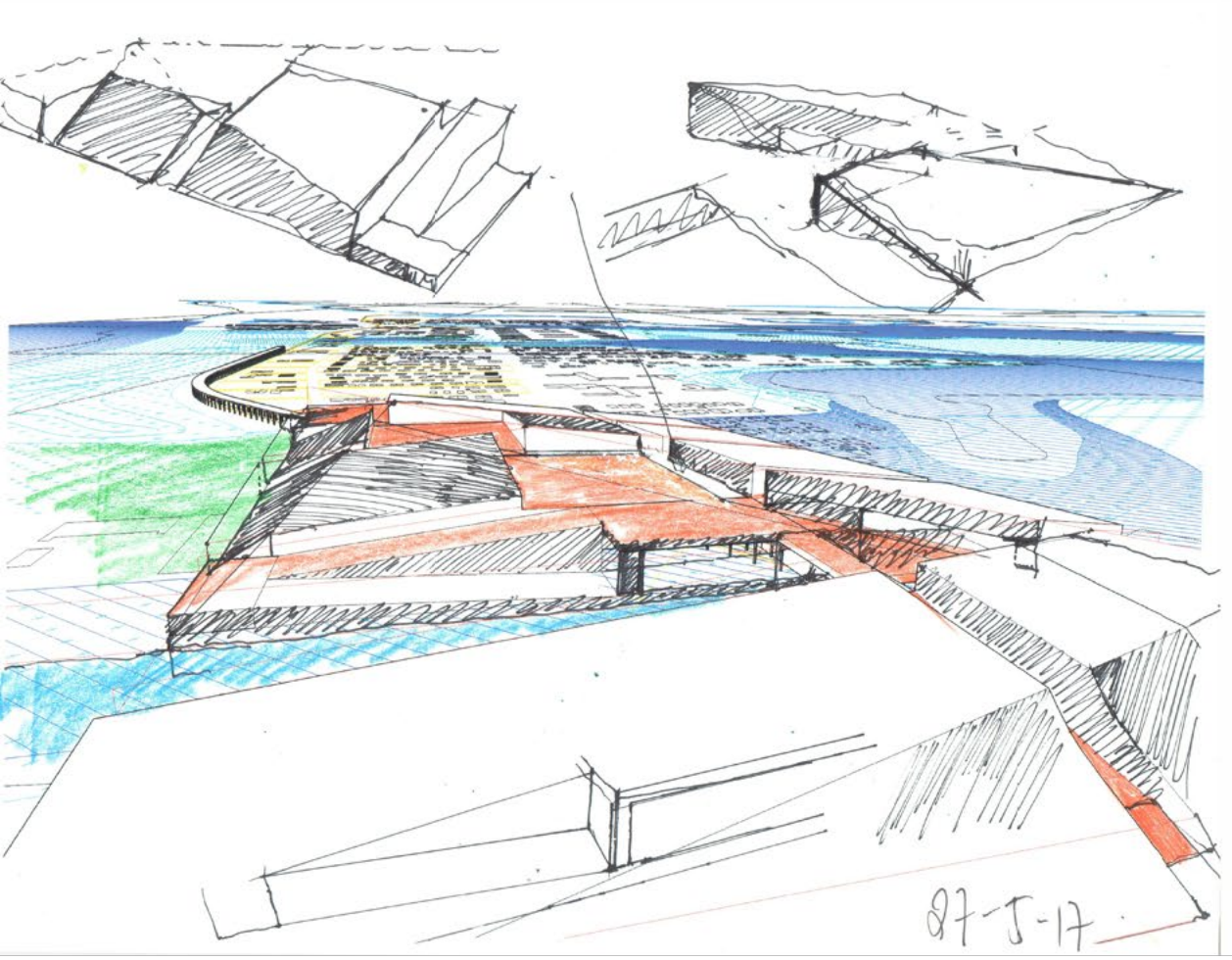









PORT Urbanism + RANGE



Coast The Bight



Rafi Segal A+U + DLANDstudio

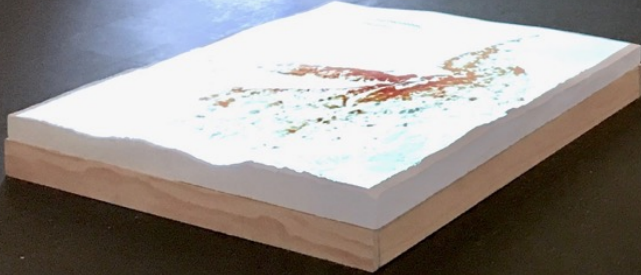





High City James Bay  
The High City changed into  
a new form of urban organization  
in the late 19th century. The  
city's growth was limited by  
the water level, and the city  
was built on a high, narrow  
peninsula. The city's growth  
was limited by the water level,  
and the city was built on a  
high, narrow peninsula. The  
city's growth was limited by  
the water level, and the city  
was built on a high, narrow  
peninsula. The city's growth  
was limited by the water level,  
and the city was built on a  
high, narrow peninsula.



***BUILDING  
HOUSING +***













Walgreens

WALGREENS AND  
OPTION CARE ARE PROUD  
TO SPONSOR THE 11TH  
ANNUAL NEW YORK CITY  
HEMOPHILIA WALK.

NYPD

nuchas

INSPIRED HAND-MADE LOOKS

ONE LETTER

Degree

DEODORANT

IT WON'T LET YOU DOWN\*

AVAILABLE AT  
Walgreens

ON 42<sup>ND</sup> ST. AND BROADWAY

P

www

Shorts  
\$12.99

NYC's best HOT DOG

SnackBox

HOTDOGS LOBST

PRETZEL

TimesSquareNYC.org

TRASH ONLY  
TimesSquareNYC.org



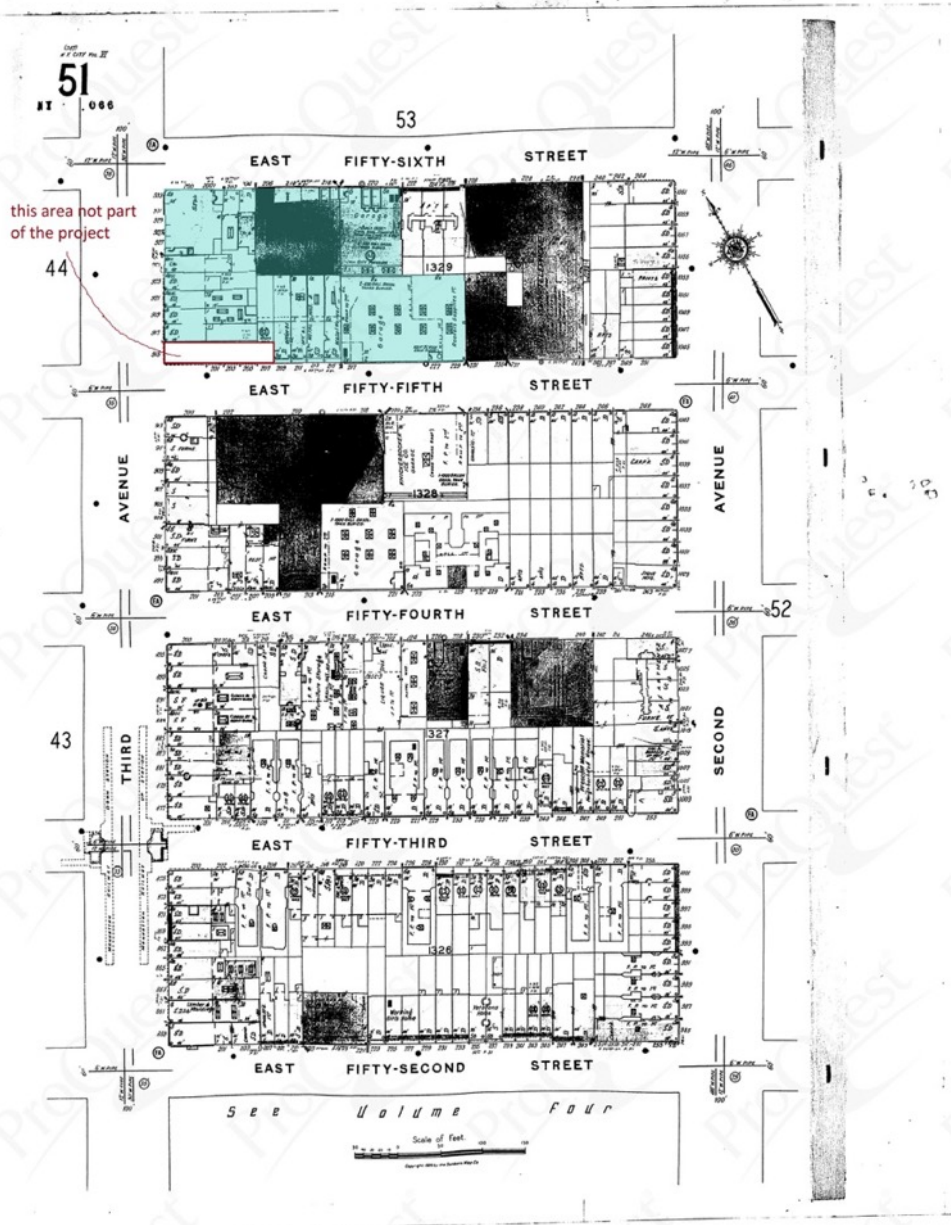

this area not part of the project





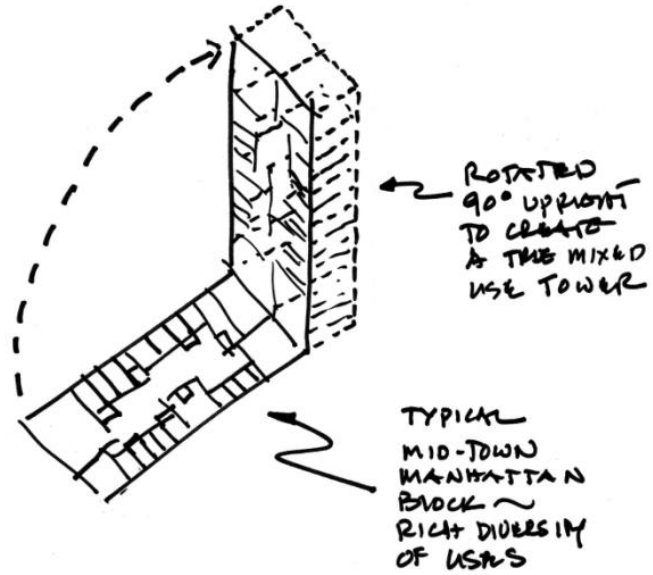

BLOCK/TOWER

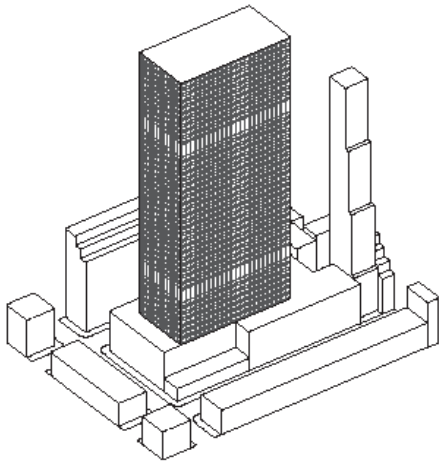

MULTI-SCALE  
multi-use/multi-tenant

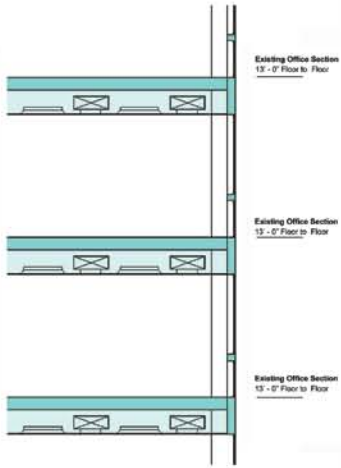

**EXISTING SECTION**  
 Obsolete Mechanical and Lighting Systems  
 Sealed Facade  
 No Sun Protection  
 Monotonous Elevation

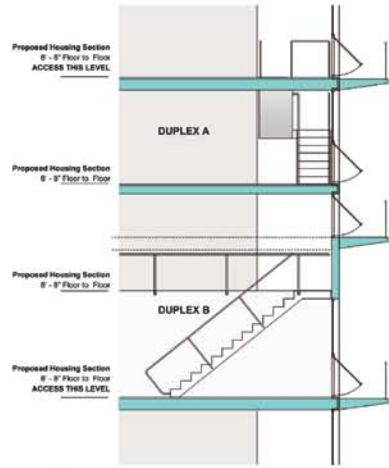

**PROPOSED HOUSING SECTION**  
 Continuous Sunshading  
 Operable Windows  
 High Efficiency Lighting  
 Variable Elevation





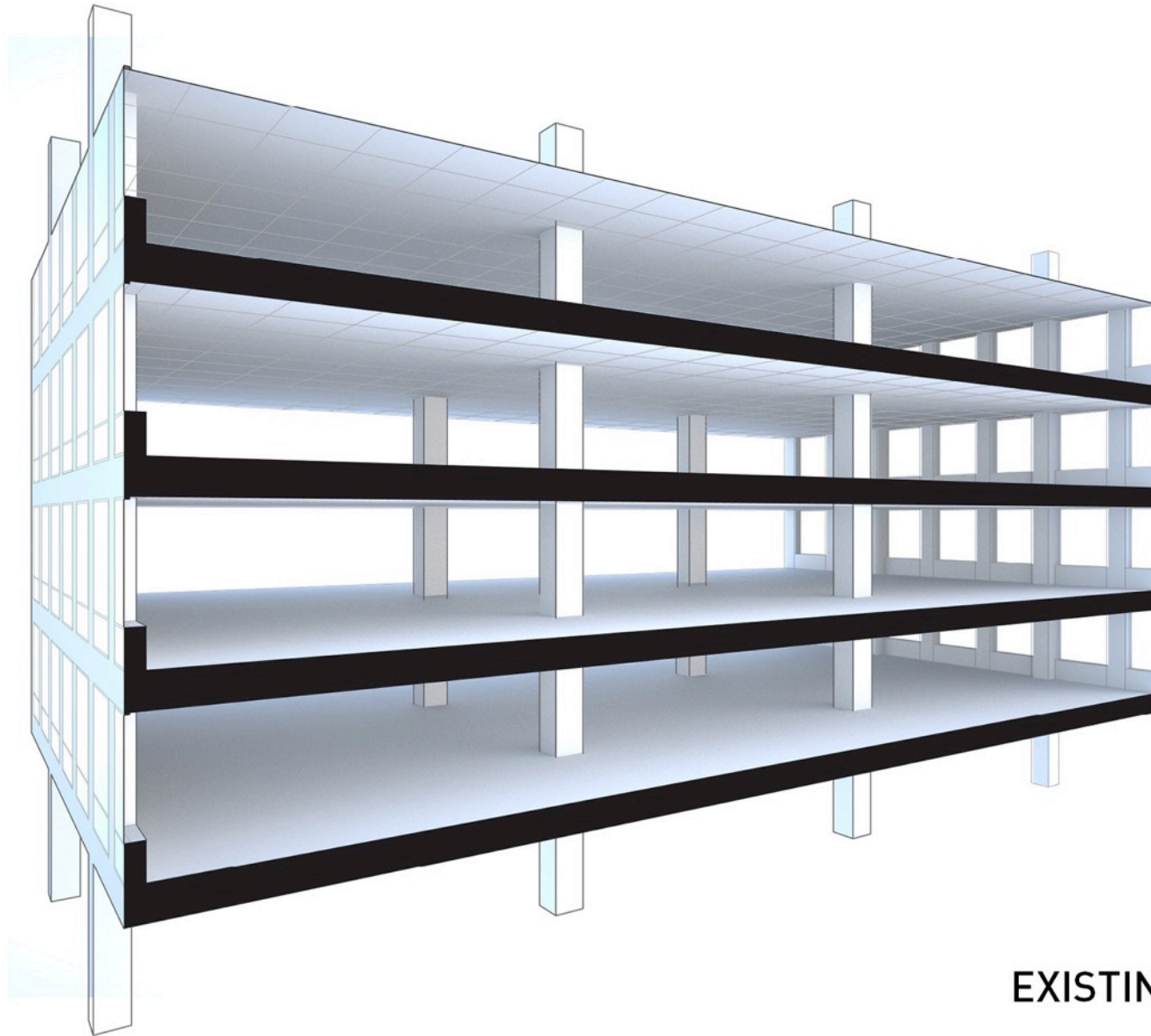

**EXISTING STRUCTURE**

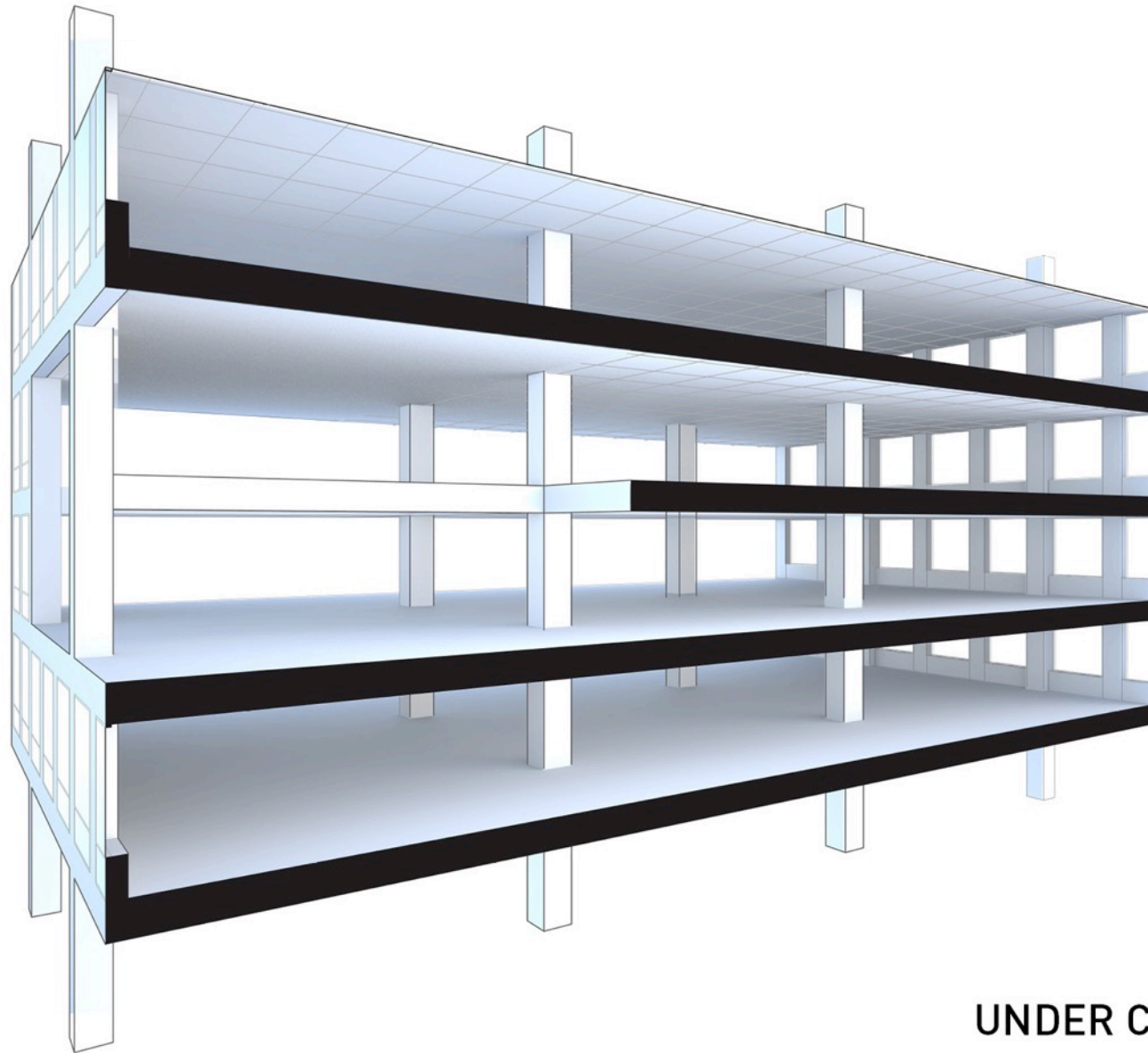

**UNDER CONSTRUCTION**



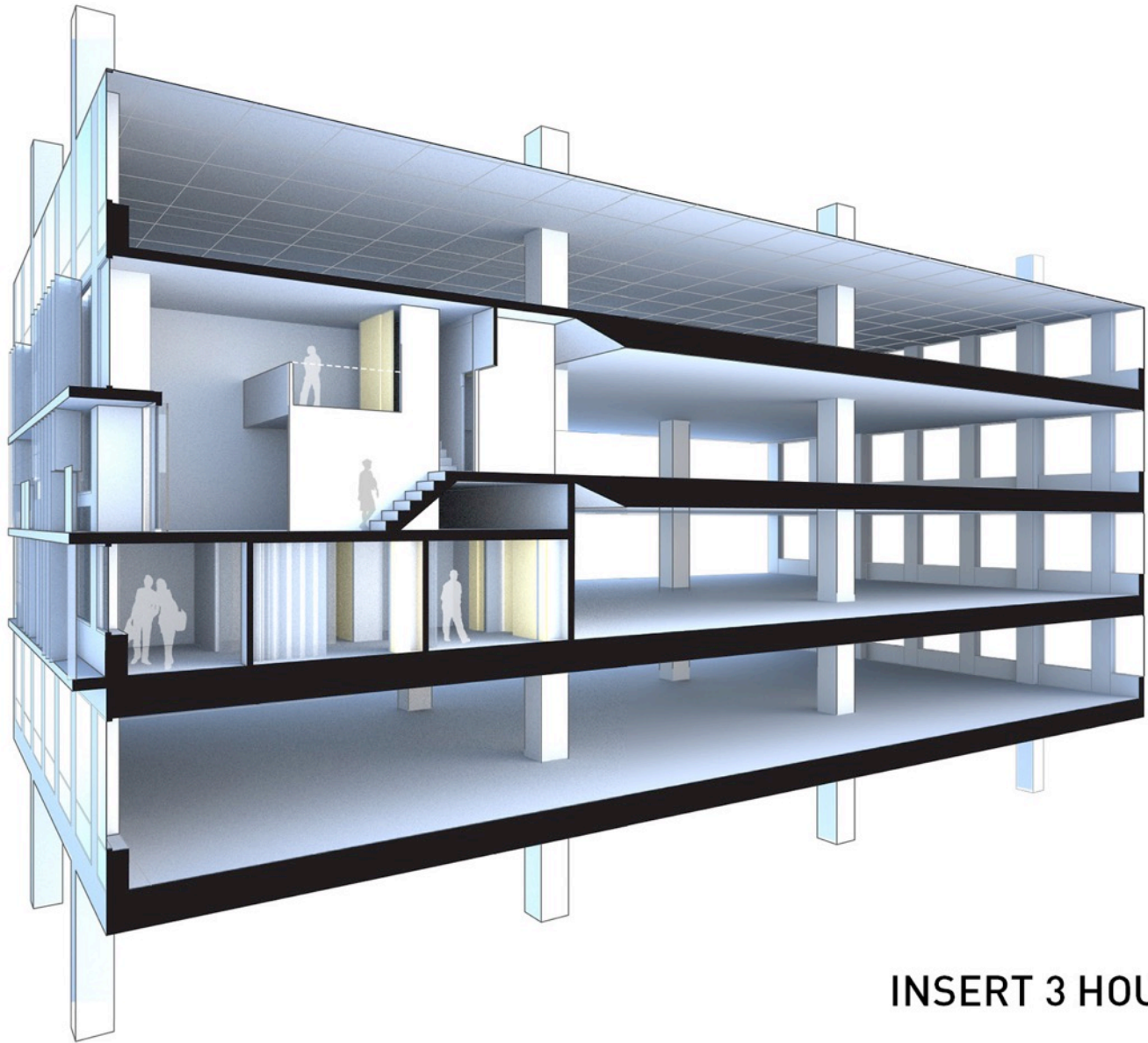

INSERT 3 HOUSING FLOORS

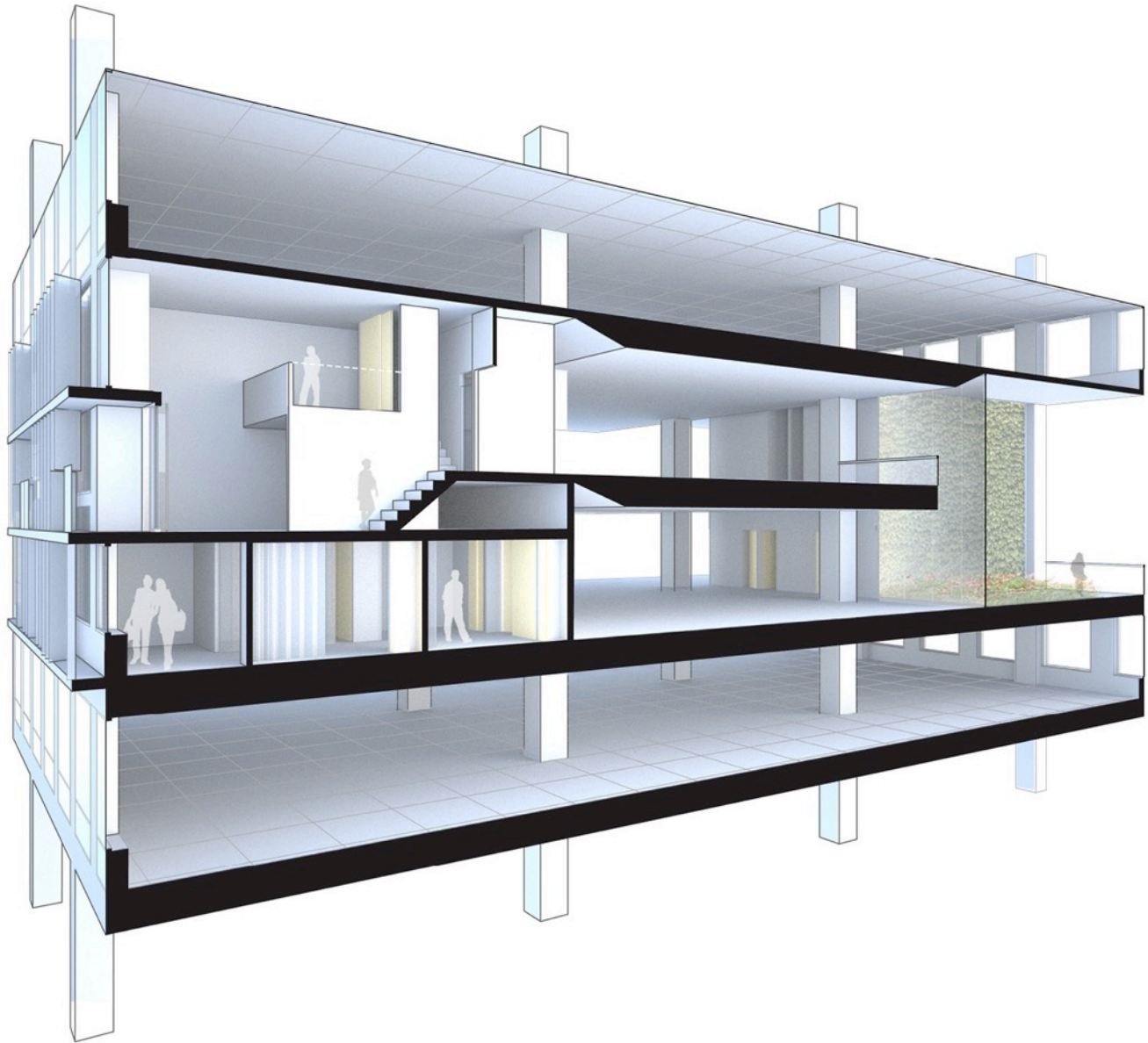



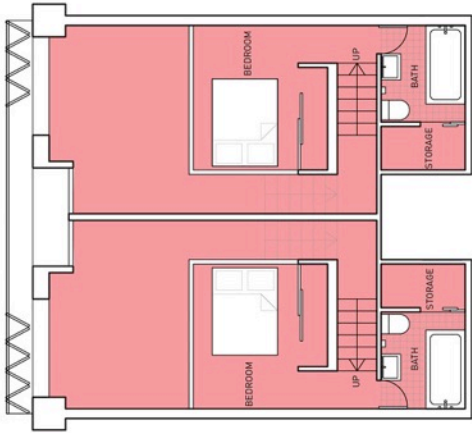

+1



ENTRY

-1

**UNIT B**  
1BR  
550 SQ. FT.

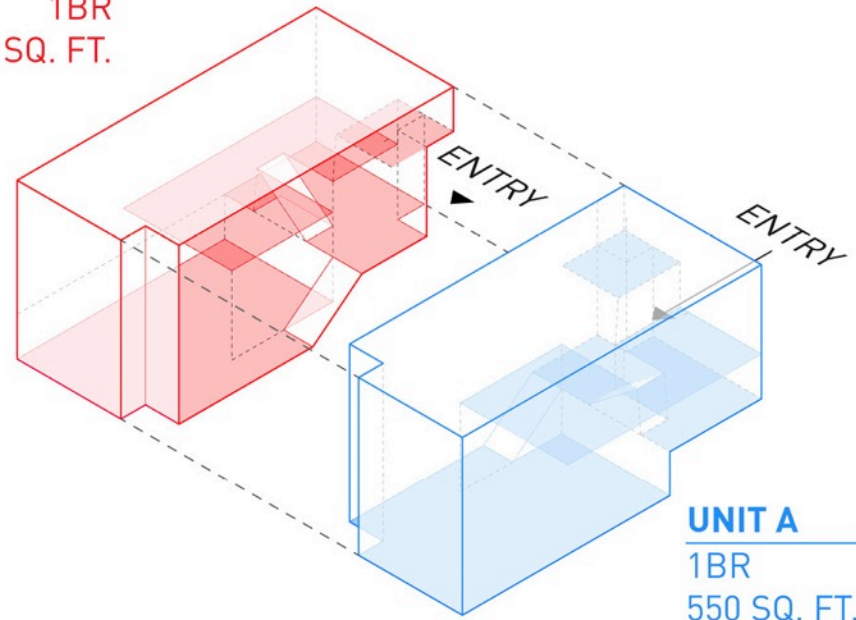

**UNIT A**  
1BR  
550 SQ. FT.

**"THE DUPLEX"**

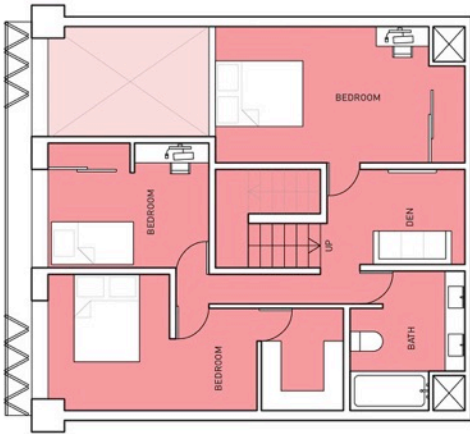

+1

**UNIT B**  
3BR  
1300 SQ. FT.

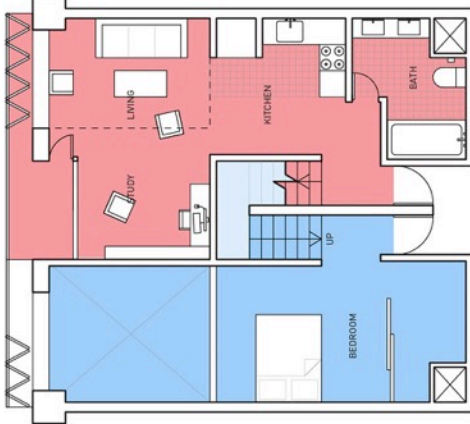

ENTRY

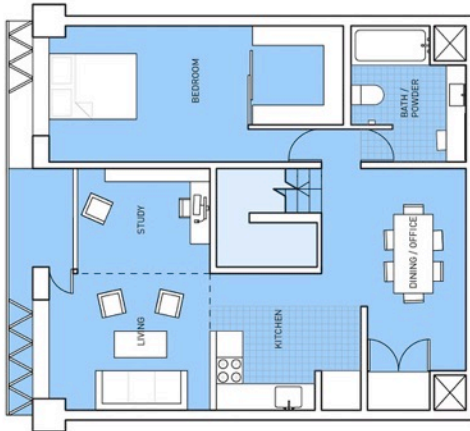

-1

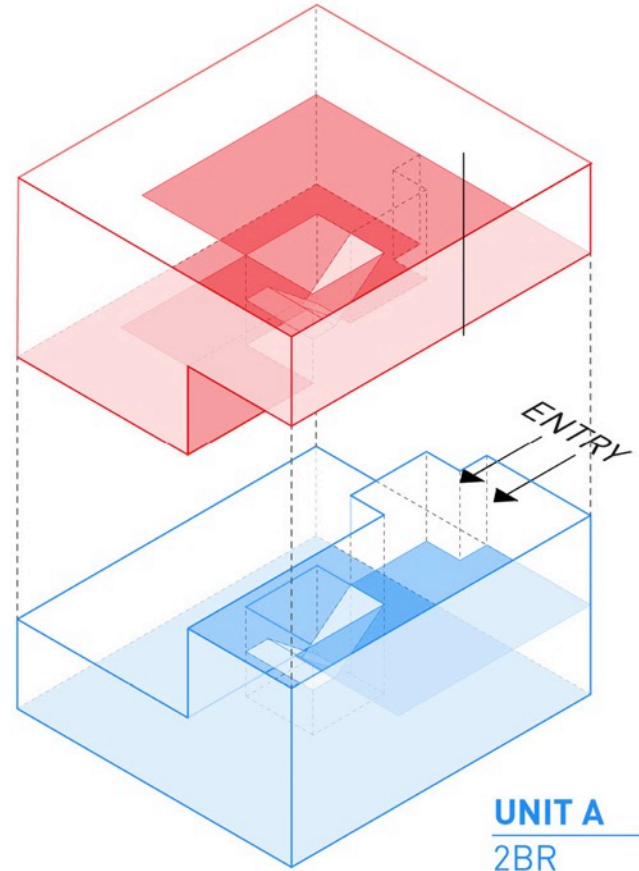

**UNIT A**  
2BR  
1150 SQ. FT.

“THE INTERLOCK”



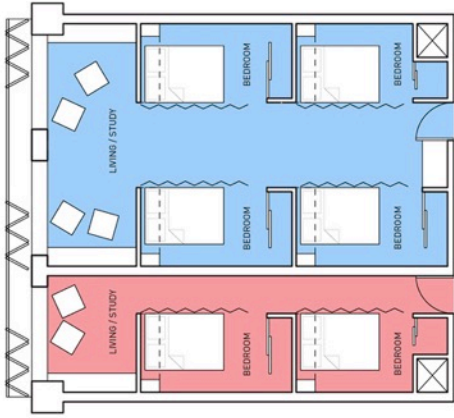

**QUAD + DUO**



**SLIM**

**QUAD**  
SLEEPS 4  
600 SQ. FT.

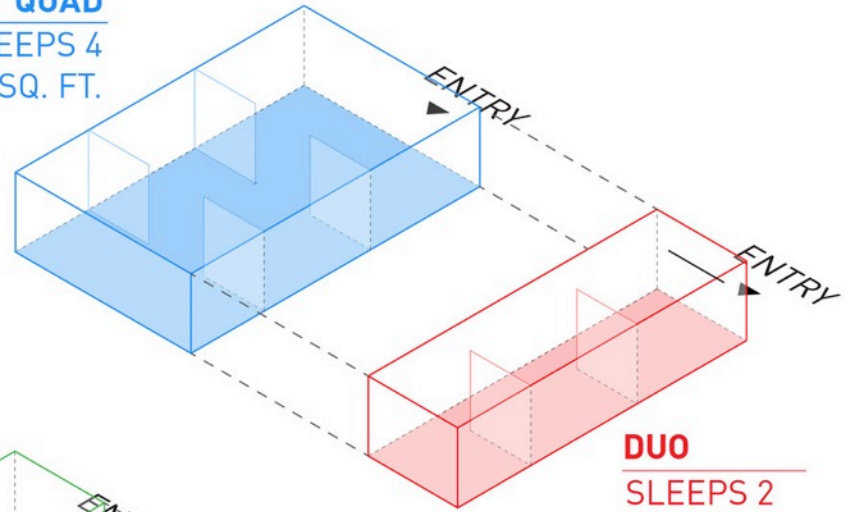

**DUO**  
SLEEPS 2  
450 SQ. FT.

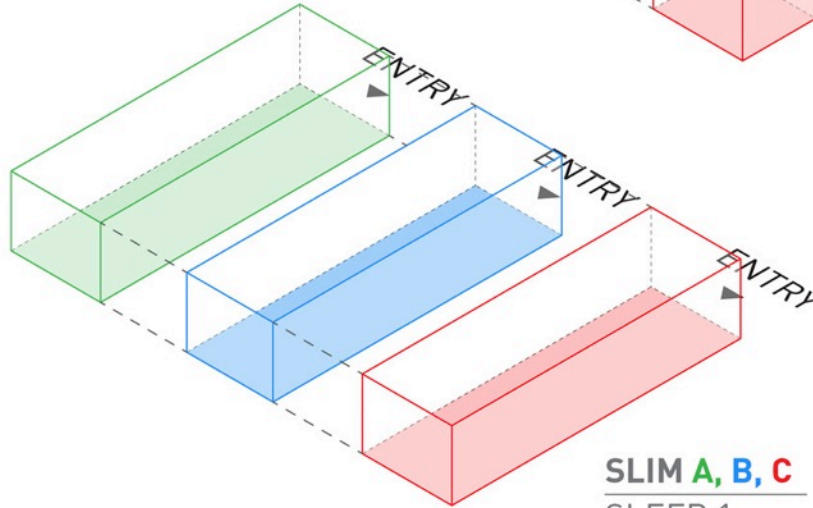

**SLIM A, B, C**  
SLEEP 1  
450 SQ. FT. EACH

**“THE SLIM”, “THE QUAD”, AND “THE DUO”**

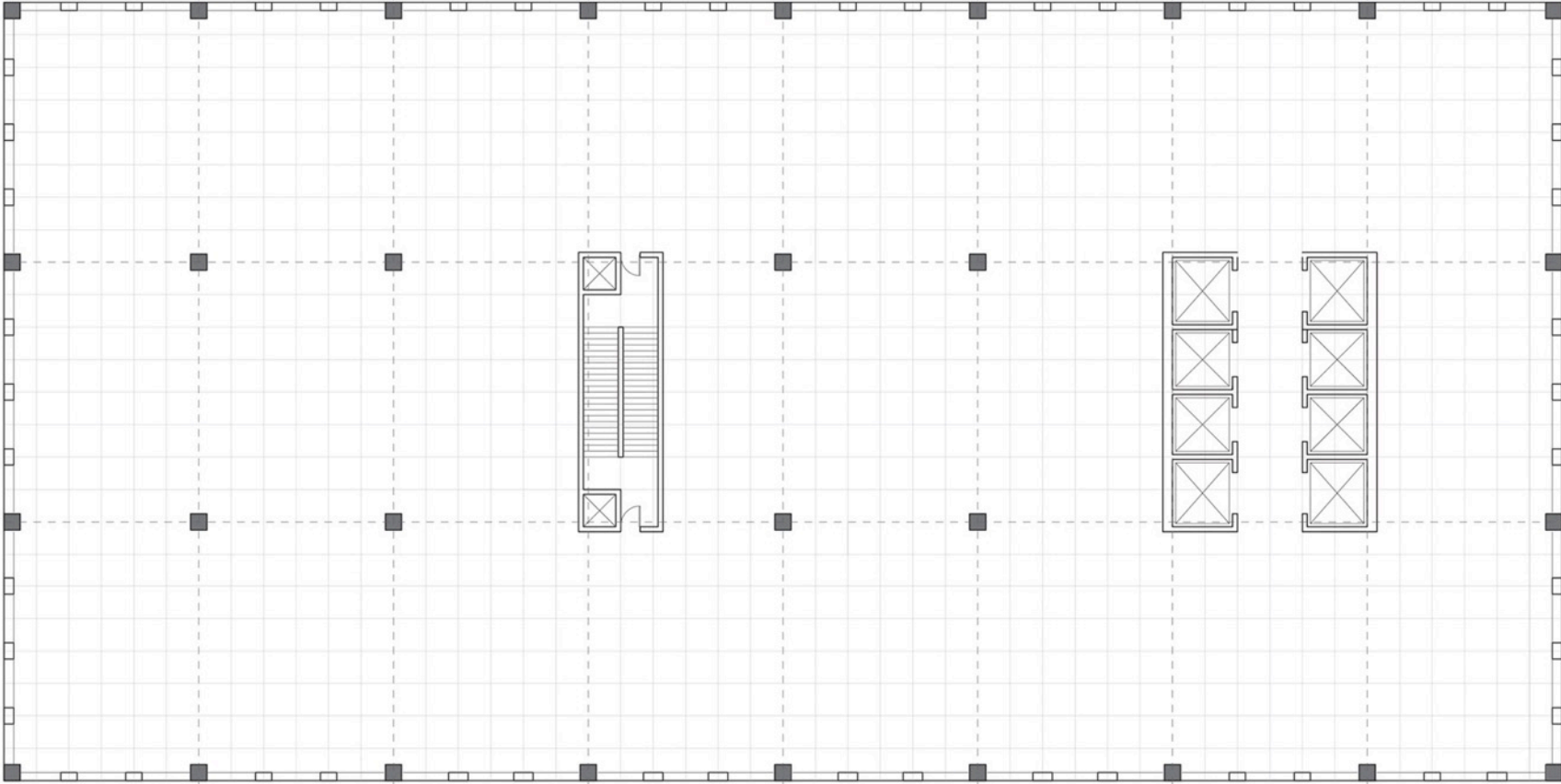



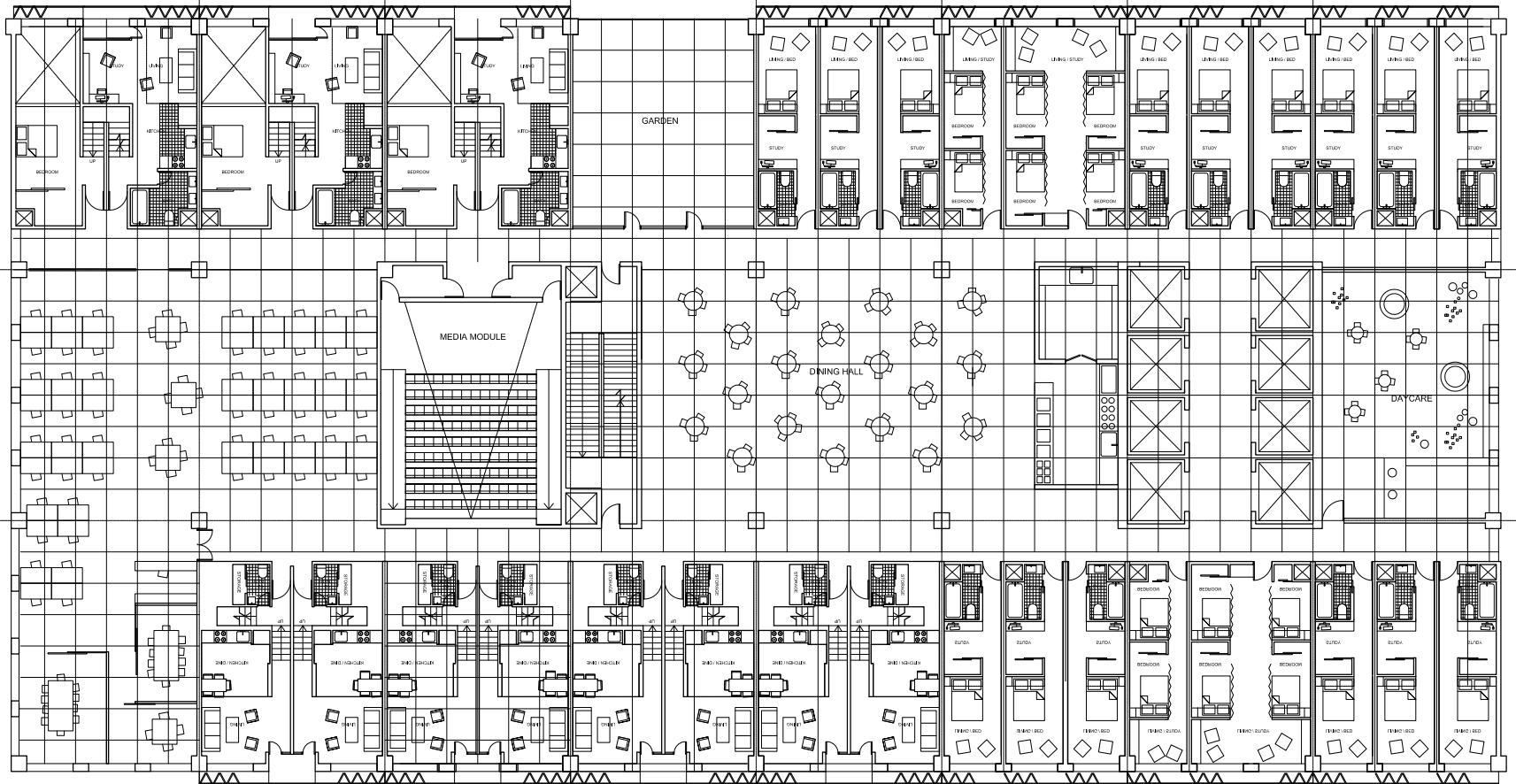

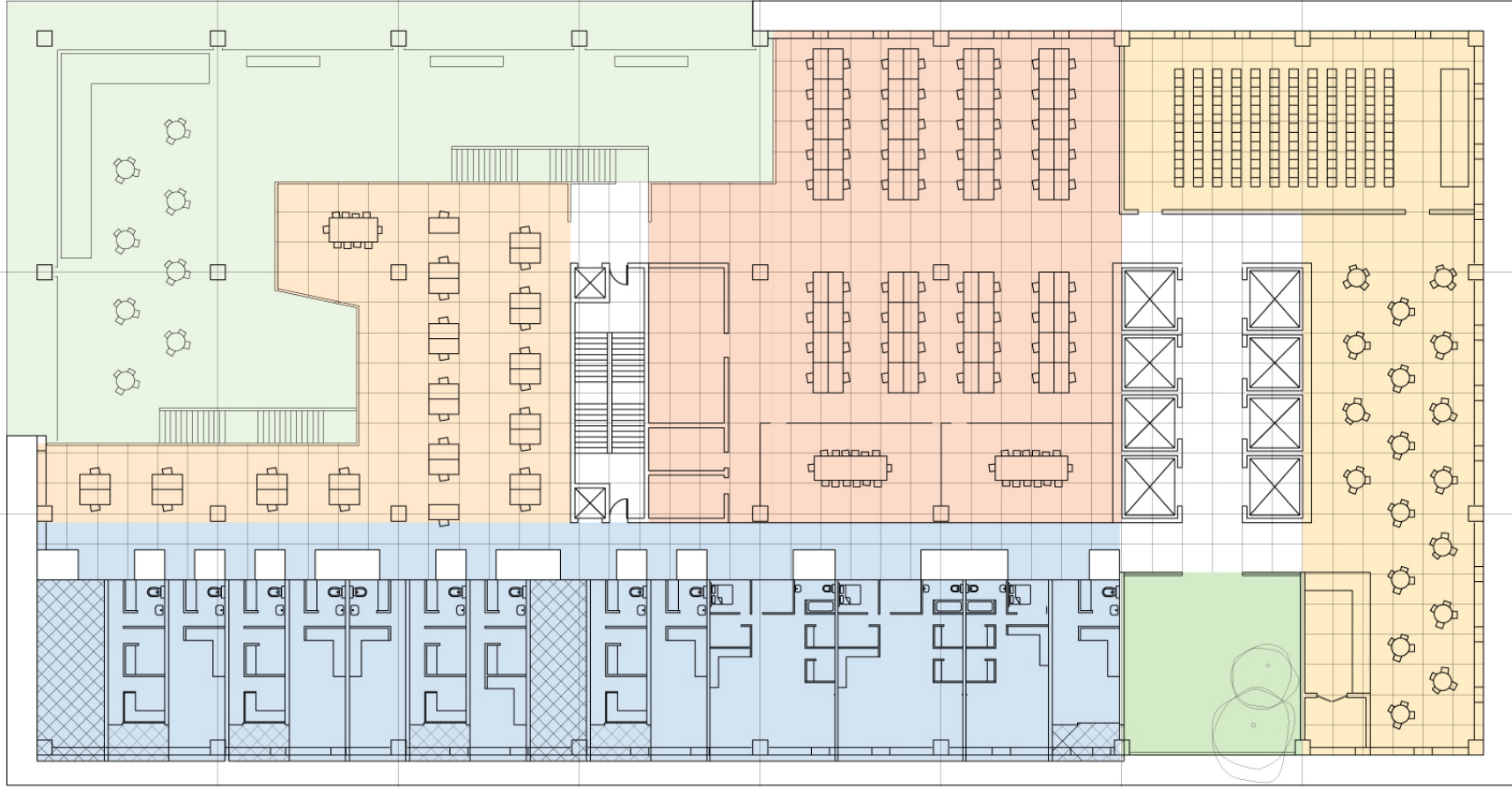





6

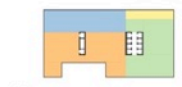

13



20

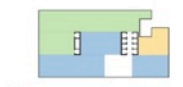

27

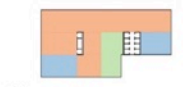

34

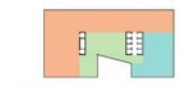

41

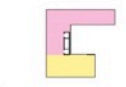

48

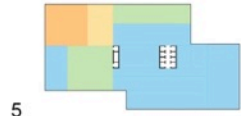

5

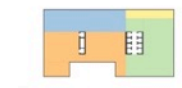

12

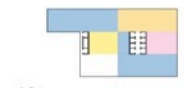

19



26

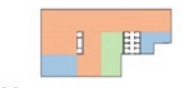

33

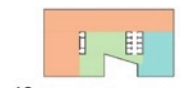

40

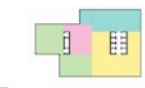

47

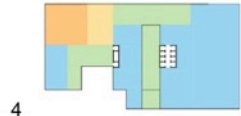

4



11



18



25

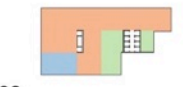

32

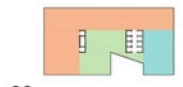

39

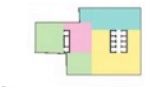

46



3

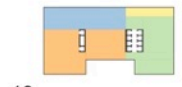

10

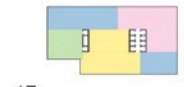

17



24

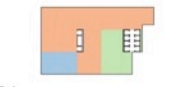

31

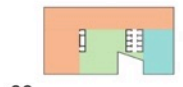

38

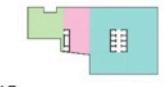

45

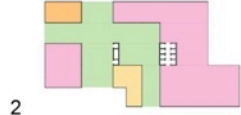

2

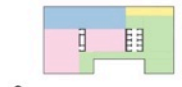

9

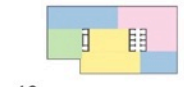

16



23



30

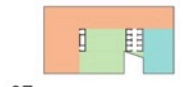

37

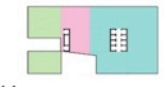

44

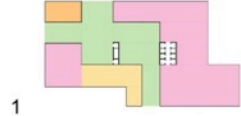

1

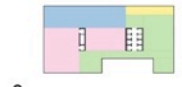

8

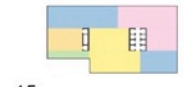

15



22



29

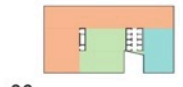

36

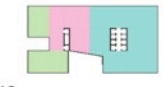

43

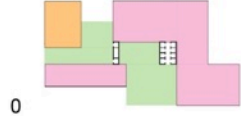

0



7

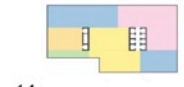

14



21

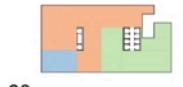

28

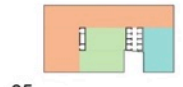

35

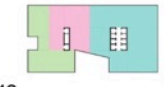

42

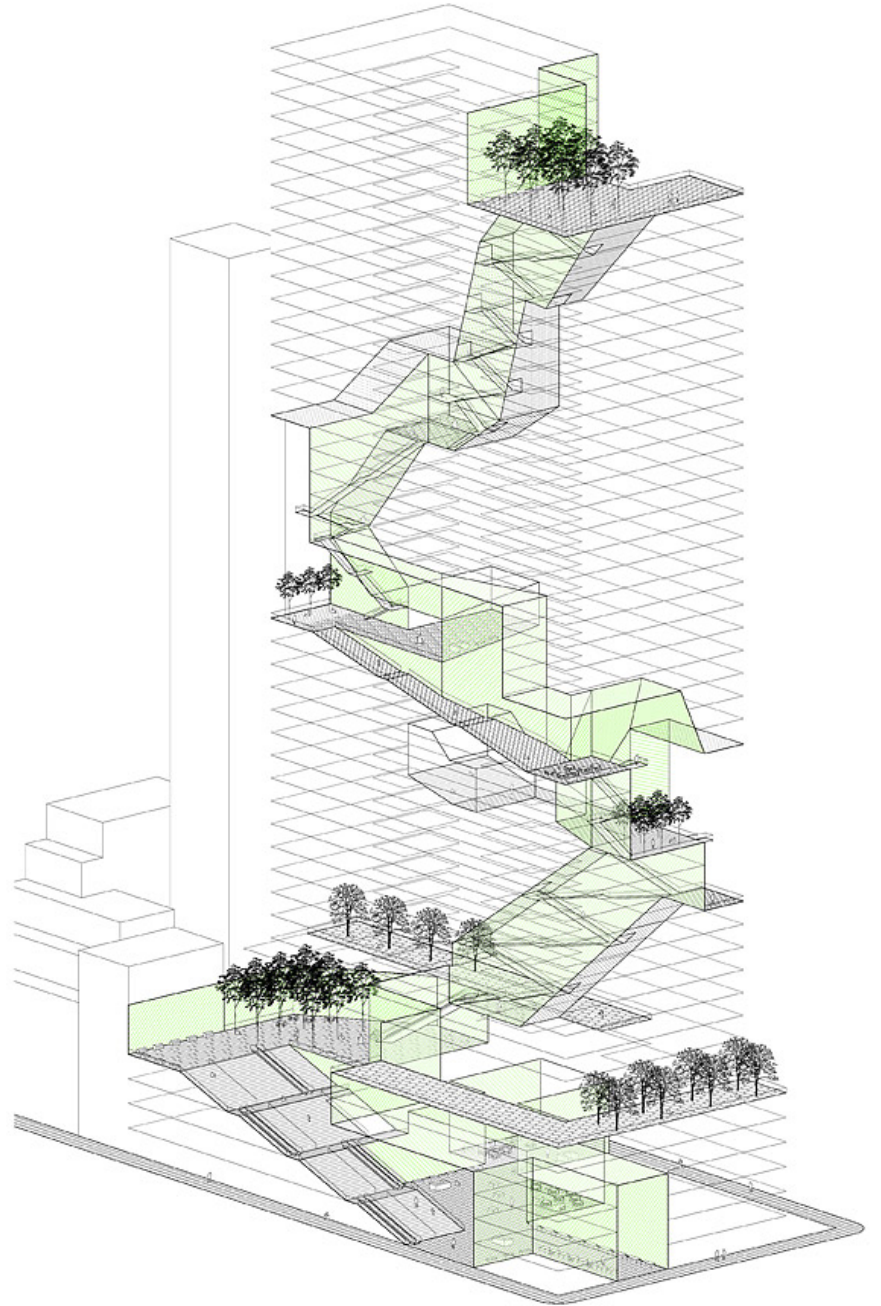
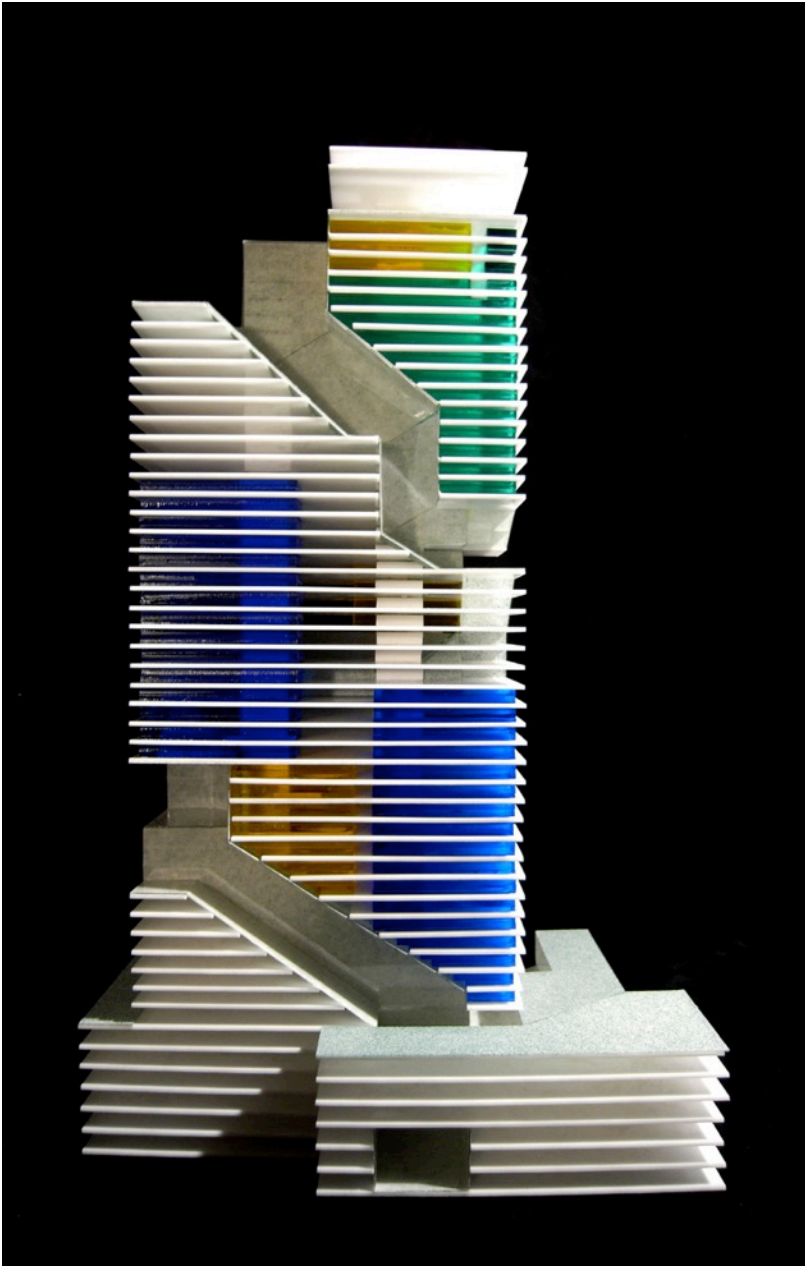









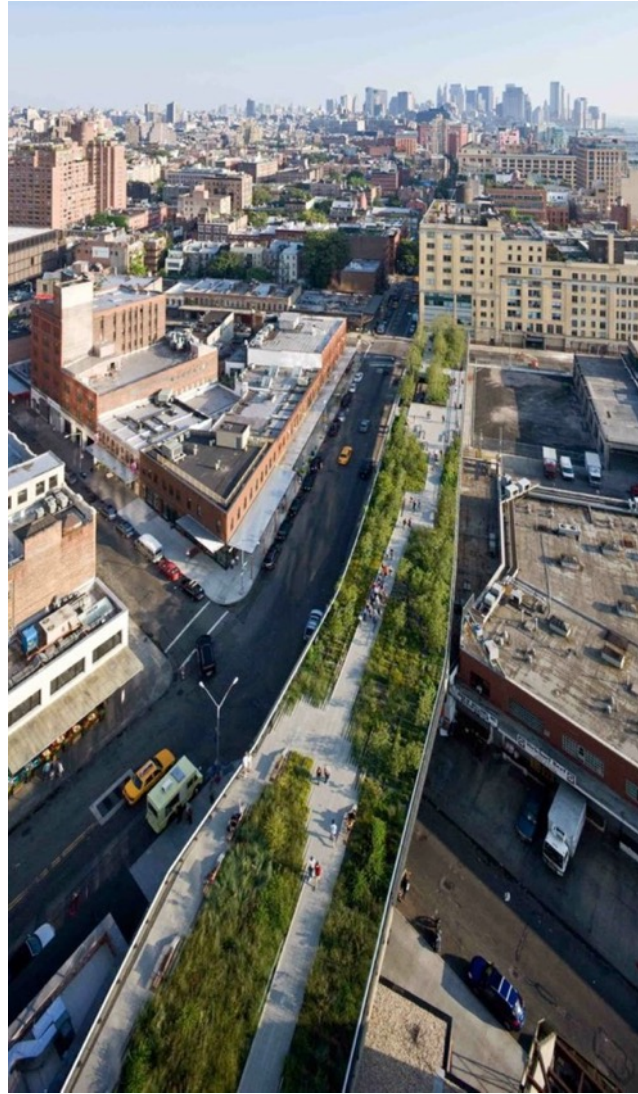
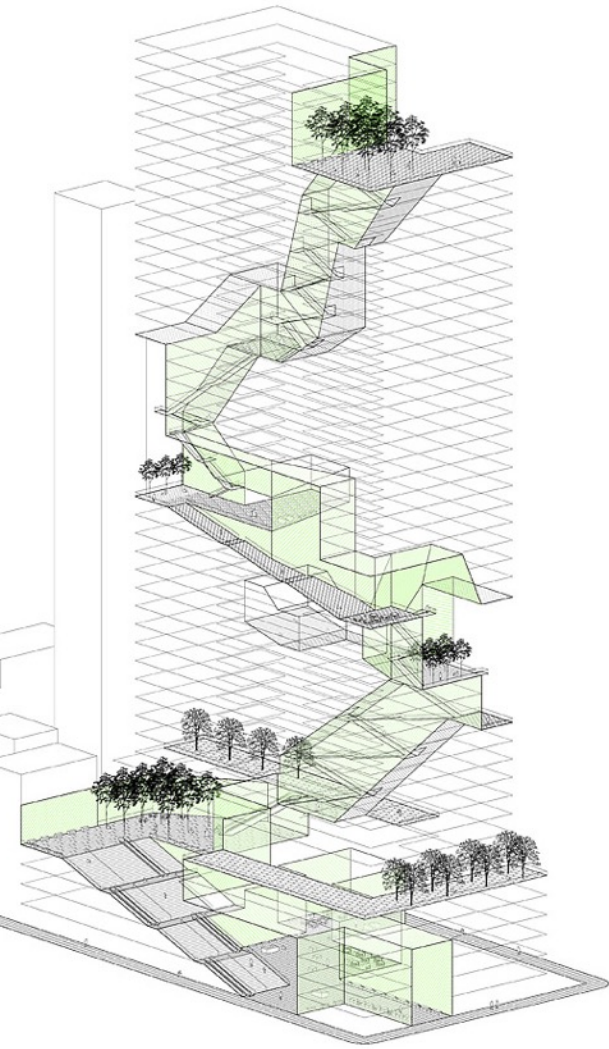









# STARTER COMMUNITIES

ARCHITECTURE AND RURAL URBANISM,  
CAVITE, PHILIPPINES



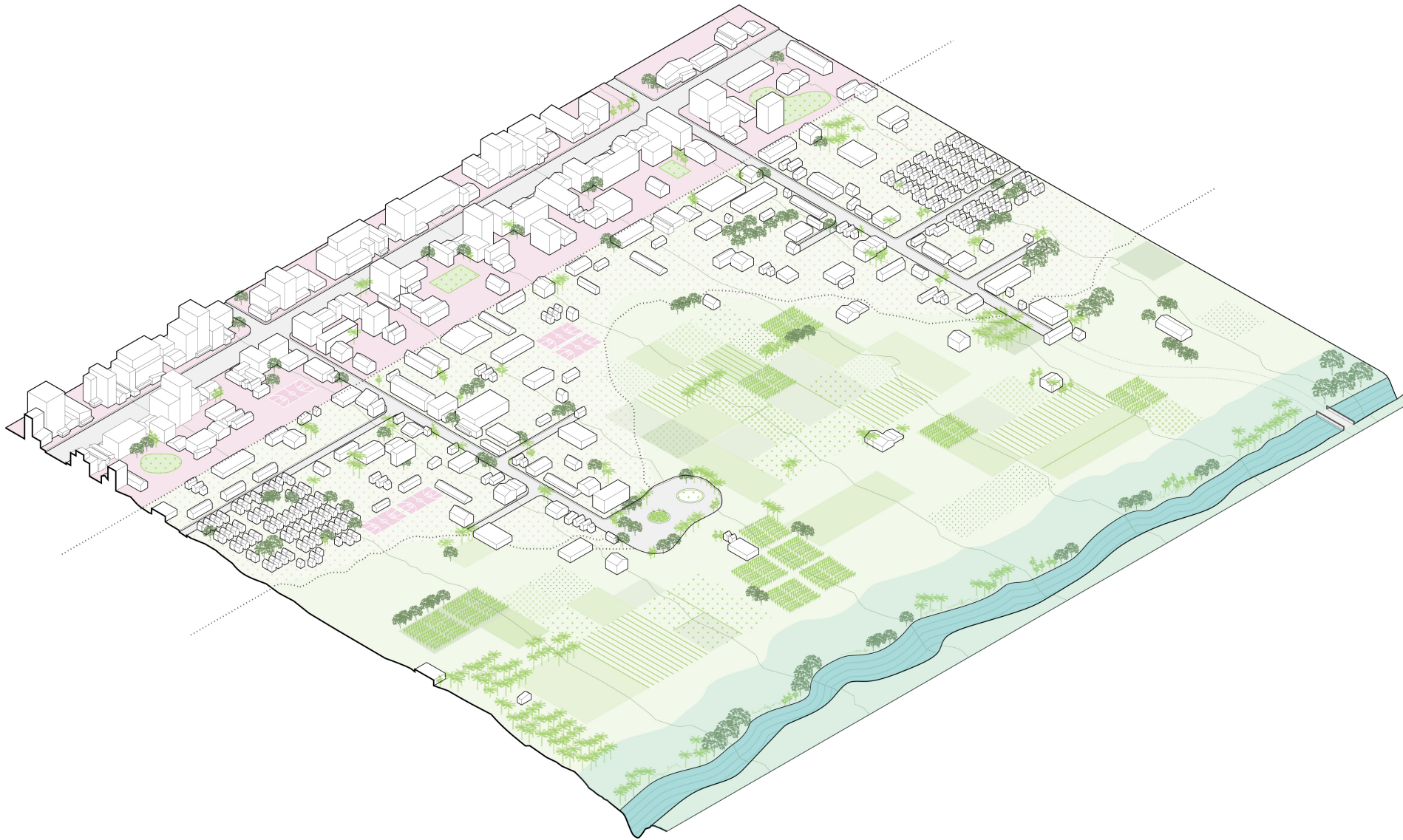





# Urbanism After Extraction

Housing, Landscape, & Infrastructure in the Katowice Agglomeration, Poland













# Institutions and Road Network

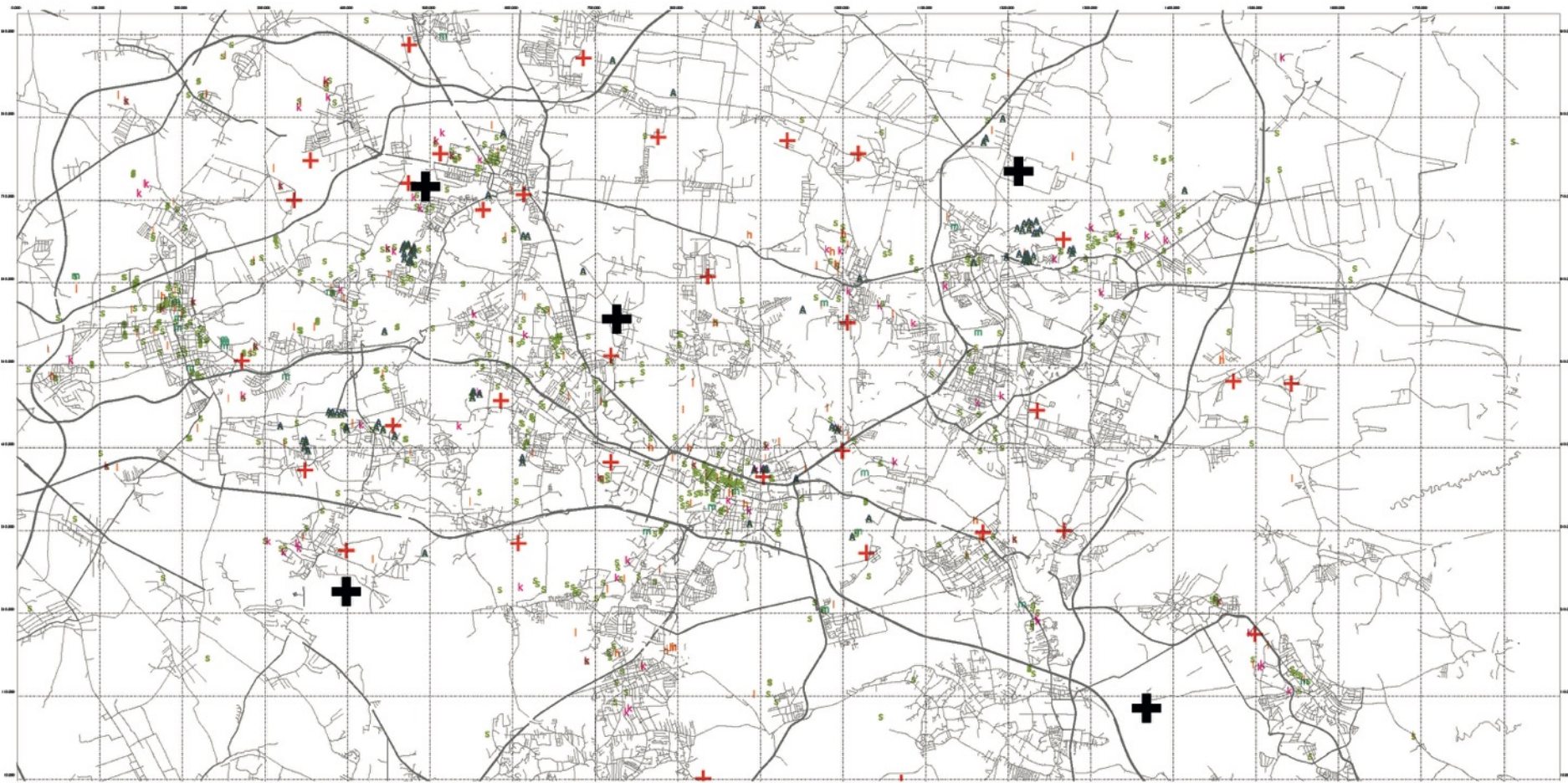

-  Mines
-  Power Plants
-  Institutions

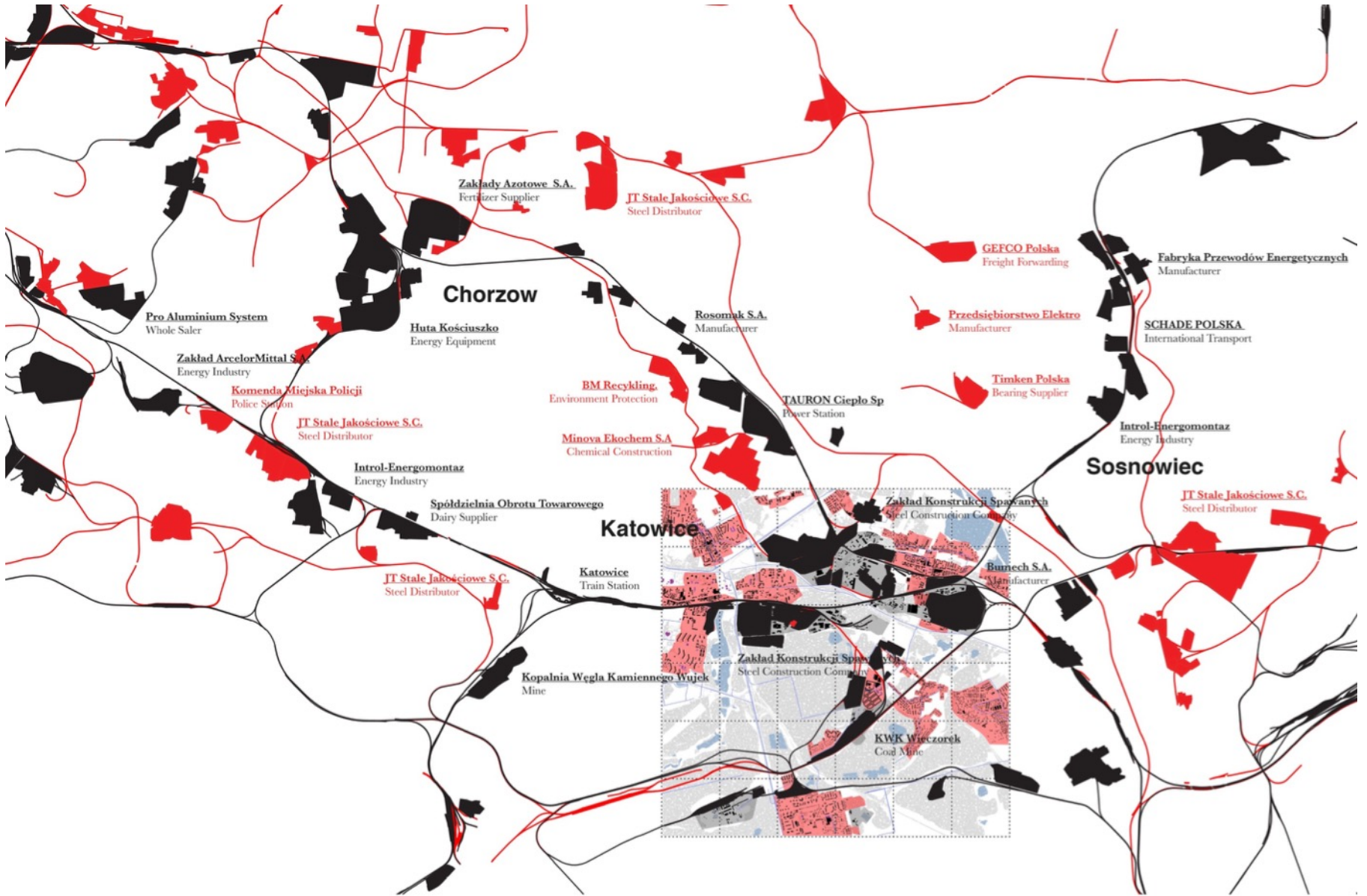

Zakłady Azotowe S.A.  
Fertilizer Supplier

JT Stale Jakościowe S.C.  
Steel Distributor

GEFCO Polska  
Freight Forwarding

Fabryka Przewodów Energetycznych  
Manufacturer

Pro Aluminium System  
Whole Saler

**Chorzow**

Huta Kościuszko  
Energy Equipment

Rosomak S.A.  
Manufacturer

Przedsiębiorstwo Elektro  
Manufacturer

SCHADE POLSKA  
International Transport

Zakład ArcelorMittal S.A.  
Energy Industry

Komenda Miejska Policji  
Police Station

JT Stale Jakościowe S.C.  
Steel Distributor

BM Recykling.  
Environment Protection

TAURON Ciepło Sp.  
Power Station

Timken Polska  
Bearing Supplier

Introl-Energomontaz  
Energy Industry

Introl-Energomontaz  
Energy Industry

Spółdzielnia Obrotu Towarowego  
Dairy Supplier

Minova Ekochem S.A.  
Chemical Construction

**Sosnowiec**

JT Stale Jakościowe S.C.  
Steel Distributor

JT Stale Jakościowe S.C.  
Steel Distributor

**Katowice**

Katowice  
Train Station

Zakład Konstrukcji Spawanych  
Steel Construction Company

Buneh S.A.  
Manufacturer

Kopalnia Węgla Kamiennego Wujek  
Mine

Zakład Konstrukcji Spawanych  
Steel Construction Company

KWK Wieszorek  
Coal Mine





# The Civic Forest

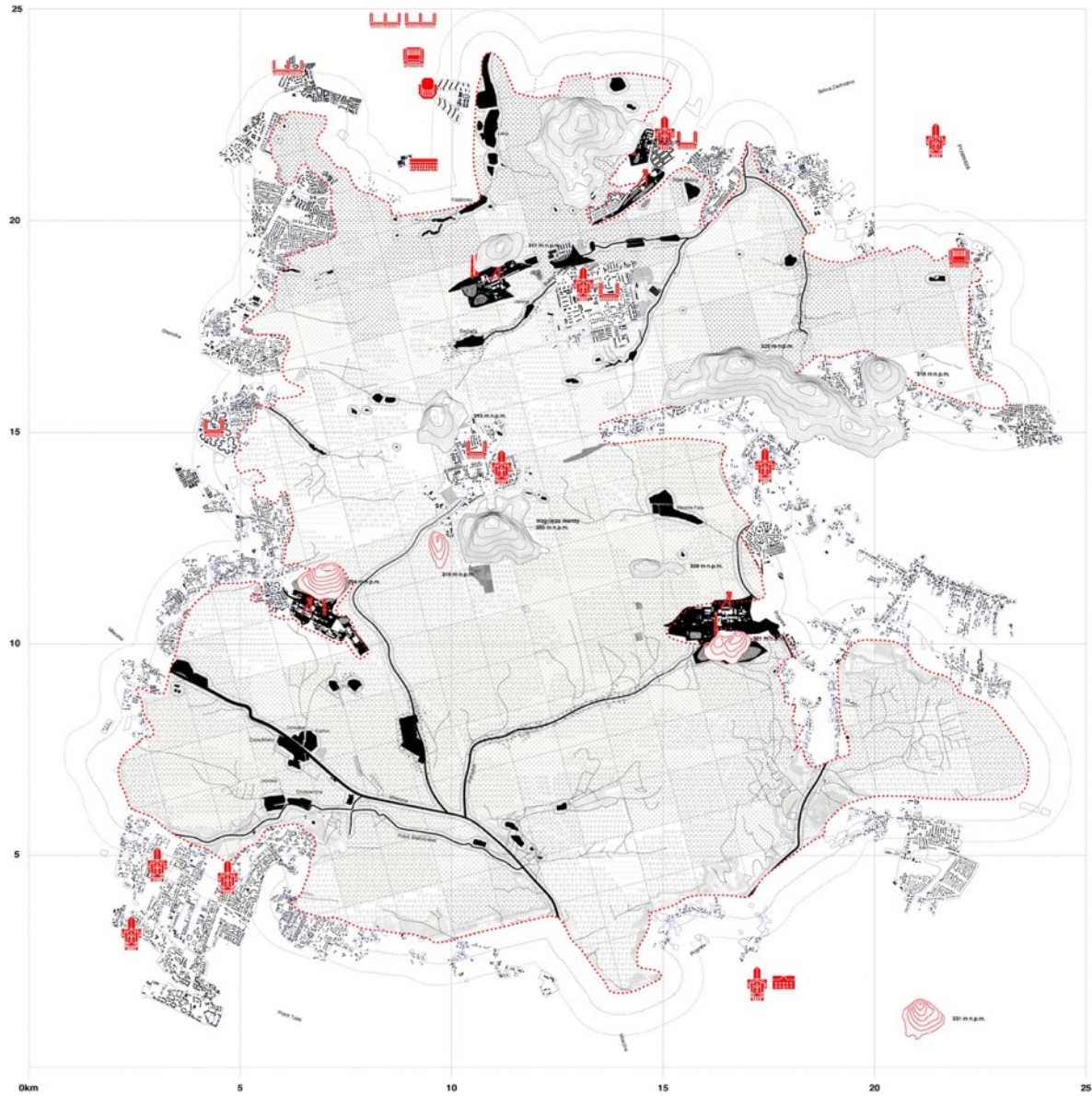

The Civic Forest  
Diana Ang, Giovanni Bellotti, Kelly Main, Alexander Wiegering



## The Golden Belt

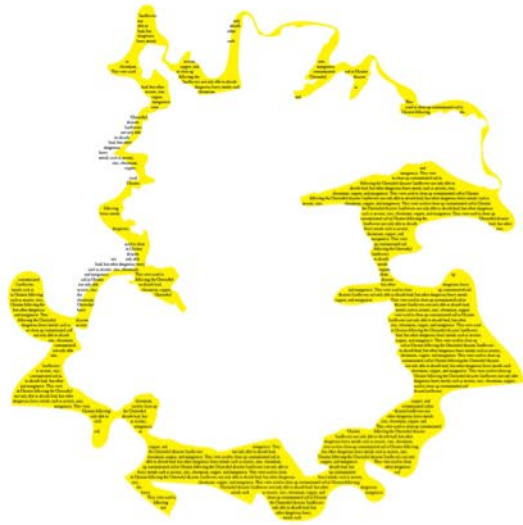

A seemingly endless sunflower field surrounds the forest. Polluted land, no longer suited for food production, becomes a place where one may think about the future. Sunflowers are not only able to absorb lead, but also other heavy metals such as arsenic, zinc, chromium, copper, and manganese. The golden field speaks optimistically of the future - one where land may be returned to agricultural use - but also gives a warning to those who enter the forest: no food may grow here today, the soil is dangerous. This was a place of violence.

## The Civic Forest



## NETWORK & PROJECT SITES

SILESIA  
BY NATURE

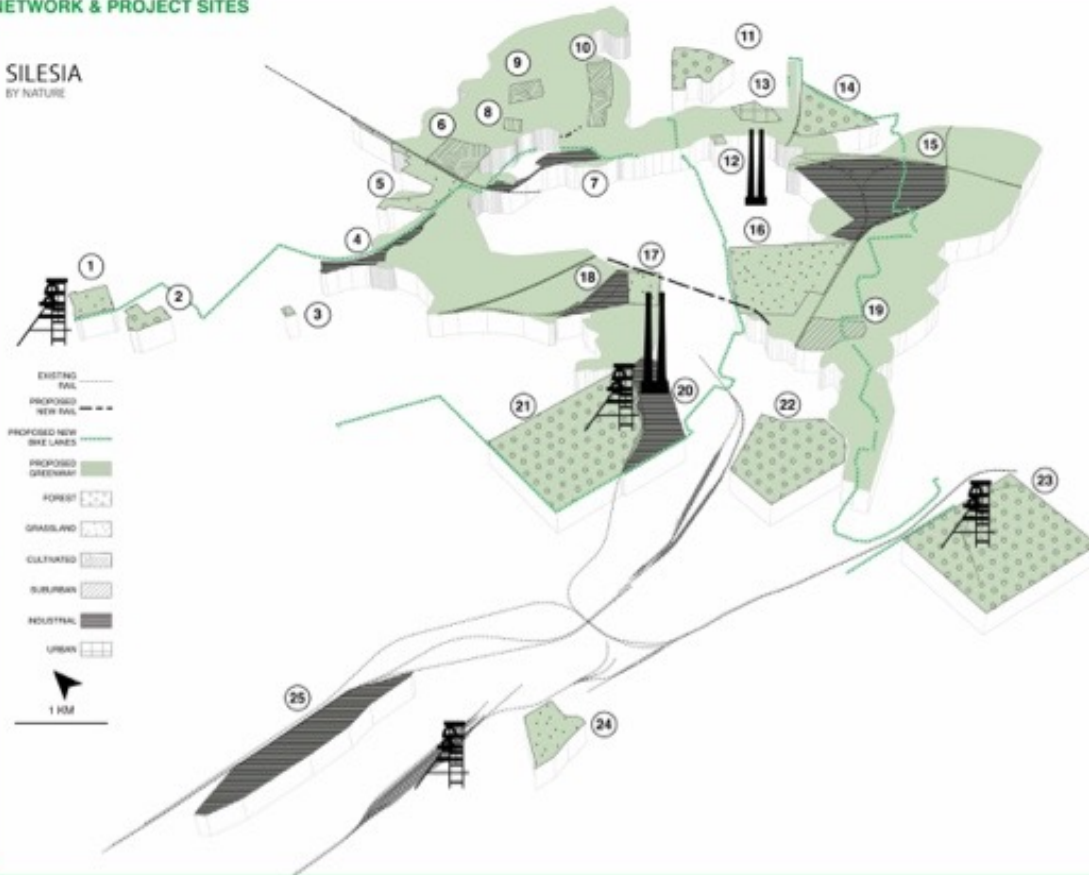

### SITE-ADJACENT ENVIRONMENTS



## PROCESS FOR ENGAGEMENT

### GET STARTED

SILESIA IS MAKING PLANS FOR THE FUTURE AND YOU CAN TOO. GET STARTED WITH A FEW QUESTIONS.

#### WHO ARE YOU?



#### WHERE IS YOUR PROJECT?



### WHAT DO YOU WANT TO DO?

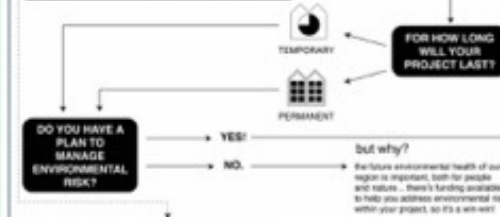

### SUPPORT IS AVAILABLE!

YOUR GROUP OR PROJECT IS LIKELY ELIGIBLE FOR ONE OR MORE FUNDING SOURCES AND USE AGREEMENTS, ESPECIALLY IF YOU ARE PLANNING TO ADDRESS ENVIRONMENTAL RISK AND IMPROVE THE HEALTH OF YOUR PROJECT SITE. GO TO [WWW.SILESIABYNATURE.PL](http://WWW.SILESIABYNATURE.PL) FOR MORE DETAILS AND FIND THE SUPPORT YOU NEED TO MAKE YOUR PROJECT A REALITY.





**How to pay?**

- DISCOUNT**: Discount on the price of the land to be developed.
- COOP & PWA**: Financial support for the preparation of future development, helping family home market.
- PLANT & PLANT**: Plant, grow, and manage in common forest ground.
- USE COLLECTED COMPOST**: Use collected compost from the area to create a forest ground.
- PLANT MEDICAL PLANTS**: Plant medical plants in the city area to create a forest ground.
- DISCOUNT ON LAND**: Discount on the price of the land to be developed.

**How to pay?**

- DISCOUNT**: Discount on the price of the land to be developed.
- COOP & PWA**: Financial support for the preparation of future development, helping family home market.
- PLANT & PLANT**: Plant, grow, and manage in common forest ground.
- USE COLLECTED COMPOST**: Use collected compost from the area to create a forest ground.
- PLANT MEDICAL PLANTS**: Plant medical plants in the city area to create a forest ground.
- DISCOUNT ON LAND**: Discount on the price of the land to be developed.

**How to pay?**



**Pick a site**

**Who are you?**

- MOTHER**: I want to plant a tree in my garden.
- WALKER**: I want to plant a tree in my garden.
- ROCKSTAR**: I want to plant a tree in my garden.
- STUDENT**: I want to plant a tree in my garden.
- GRANDPA**: I want to plant a tree in my garden.
- CHILD**: I want to plant a tree in my garden.

**Start here**

Silesia is making plans for the future and so can you

Find a site. Make a plan. Get some funding. Make it safe. Get started.

**Start here**

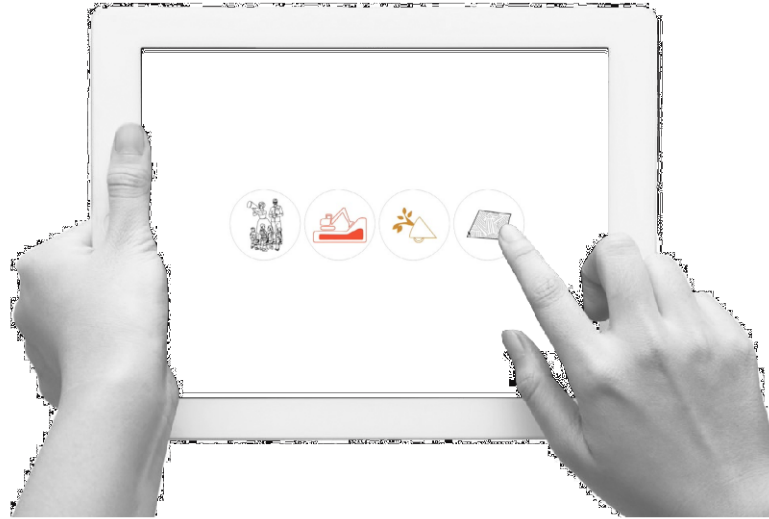

*SilesiaByNayture.pl provides both informational resources about the project and a platform for citizen engagement*